



SERVICE NOTEBOOK
BUILT-IN ELECTRIC WALL OVEN

Models

VESO127SS
VESO527SS
VEDO127SS
VEDO527SS
VESO130SS
VESO530SS
VEDO130SS
VEDO530SS
DESO127SS
DESO527SS
DEDO127SS
DEDO527SS
DESO130SS
DESO530SS
DEDO130SS
DEDO530SS



VIKING RANGE CORPORATION
111 Front Street, Greenwood, Mississippi (MS) 38930 USA 662-455-1200



Important Information

SAVE THESE INSTRUCTIONS

REVIEW ALL SERVICE INFORMATION IN THE APPROPRIATE SERVICE MANUAL AND TECHNICAL SHEETS BEFORE BEGINNING REPAIRS.

Pride and workmanship go into every product to provide our customers with quality products. It is possible, however, that during its lifetime, a product may require service. Products should be serviced only by a qualified service technician that is familiar with the safety procedures required in the repair and who is equipped with the proper tools, parts, testing instruments, and the appropriate service manual.

Safety Information

This manual uses safety symbols to inform the qualified service technician of possible hazards that may be present during a service procedure. They will appear as follows:

DANGER: IMMEDIATE HAZARDS WHICH WILL RESULT IN SEVERE PERSONAL INJURY OR DEATH.

WARNING: Hazards or unsafe practices which COULD result in severe personal injury or death.

CAUTION: Hazards or unsafe practices which COULD result in minor personal injury or product or property damage.

Note to Customer

If you perform service on your own Viking product, you must assume responsibility of personal injury or property damage which may result.

Viking will not be responsible for injury or property damage arising from service performed by anyone other than Viking Factory Authorized Service Agencies.

WARNING: To avoid risk of serious injury or death, repairs should not be attempted by unauthorized personnel.

CAUTION: VIKING will not be responsible for any injury or property damage from improper service procedures. If performing service on your own product, you must assume responsibility for any personal injury or property damage which may result.

To locate an authorized servicer, call:

Viking Technical Service
Phone No. 1-800-914-4799

Address your written correspondence to:

Viking Preferred Service
111 Front Street
P.O. Drawer 956
Greenwood, MS 38935-0956



Professional Series Built-In Electric Ovens Warranty

One Year Full Warranty

Built-in electric ovens and all of their component parts and accessories, except as detailed below*, are warranted to be free from defective materials or workmanship in normal household use for a period of twelve (12) months from the date of original retail purchase. Viking Range Corporation, warrantor, agrees to repair or replace, at its option, any part which fails or is found to be defective during the warranty period.

*Glass (including light bulbs), painted and decorative items are warranted to be free from defective materials or workmanship for a period of ninety (90) days from the date of original retail purchase. **ANY DEFECTS MUST BE REPORTED TO THE SELLING DEALER WITHIN NINETY (90) DAYS FROM DATE OF ORIGINAL RETAIL PURCHASE.**

Viking Range Corporation uses the most up-to-date processes and best materials available to produce all color finishes. However, slight color variation may be noticed because of the inherent differences in painted parts and porcelain parts as well as differences in kitchen lighting, product locations, and other factors.

Five Year Limited Warranty

Any bake element, broil element, or convection cook element which fails due to defective materials or workmanship in normal household use during the second through the fifth year from the date of original retail purchase will be repaired or replaced, free of charge for the part itself, with the owner paying all other costs, including labor.

Ten Year Limited Warranty

Any porcelain oven or porcelain inner door panel which rusts through due to defective materials or workmanship in normal household use during the second through the tenth year from the date of original retail purchase will be repaired or replaced, free of charge for the part itself, with the owner paying all other costs, including labor.

This warranty extends to the original purchaser of the product warranted hereunder and to each transferee owner of the product during the term of the warranty.

This warranty shall apply to products purchased and located in the United States and Canada. Products must be purchased in the country where service is requested. Warranty labor shall be performed by an authorized Viking Range Corporation service agency or representative. Warranty shall not apply to damage resulting from abuse, accident, natural disaster, loss of electrical power to the product for any reason, alteration, outdoor use, improper installation, improper operation, or repair or service of the product by anyone other than an authorized Viking Range Corporation service agency or representative. This warranty does not apply to commercial usage. Warrantor is not responsible for consequential or incidental damage whether arising out of breach of contract, or otherwise. Some jurisdictions do not allow the exclusion or limitation of incidental or consequential damages, so the above limitation or exclusion may not apply to you.

Owner shall be responsible for proper installation, providing normal care and maintenance, providing proof of purchase upon request, and making the appliance reasonably accessible for service. If the product or one of its component parts contain a defect or malfunction during warranty period, after a reasonable number of attempts by the warrantor to remedy the defects or malfunction, the owner is entitled to either a refund or replacement of the product or its component part or parts. Warrantor's liability on any claim of any kind, with respect to the goods or services covered hereunder, shall in no case exceed the price of the goods or service or part thereof which gives rise to the claim.

WARRANTY SERVICE: Under the terms of this warranty, service must be performed by a factory authorized Viking Range Corporation service agent or representative. Service will be provided during normal business hours, and labor performed at overtime or premium rates shall not be covered by this warranty. To obtain warranty service, contact the dealer from whom the product was purchased, an authorized Viking Range Corporation service agent, or Viking Range Corporation. Provide model and serial number and date of original purchase. For the name of your nearest authorized Viking Range Corporation service agency, call the dealer from whom the product was purchased or Viking Range Corporation. **IMPORTANT:** Retain proof of original purchase to establish warranty period.

The return of the Owner Registration Card is not a condition of warranty coverage. You should, however, return the Owner Registration Card so the Viking Range Corporation can contact you should any question of safety arise which could affect you.

Any implied warranties of merchantability and fitness applicable to the above described bake element, broil element, convection cook element, porcelain oven, or porcelain inner door panel are limited in duration to the period of coverage of the applicable express written limited warranties set forth above. Some jurisdictions do not allow limitations on how long an implied warranty lasts, so the above limitation may not apply to you. This warranty gives specific legal rights, and you may also have other rights which may vary from jurisdiction to jurisdiction.

VIKING RANGE CORPORATION
111 Front Street, Greenwood, Mississippi (MS) 38930 USA 662-455-1200

Specifications are subject to change without notice.
For more product information, call 1-888-VIKING1 (845-4641), or visit our web site at <http://www.vikingrange.com>



Table of Contents

Important Information	2
Safety Information	2
Note to Customer	2
General Overview	6
Specifications.....	7
Serial Number Location.....	8
Model Numbers	8
Serial Numbers	8
Operation.....	9
Oven Control Panel.....	9
Oven Preheat Chart.....	10
Oven Settings and Functions	11
Clock and Timers.....	13
Self-Clean Cycle.....	17
Service Procedures	18
Part Locator.....	18
Service Situation Chart	19
Partial Oven Removal.....	20
Full Oven Removal.....	20
Door Assembly Removal.....	21
Door Gasket Removal.....	21
Outer Door Panel Removal.....	22
Outer Door Glass Removal.....	22
Inner Door Glass Removal	23
Door Handle Removal	23
Door Hinge Removal	24
Oven Rack Removal	24
Glide Rack	24
Standard Rack	24
Oven Rack Support Removal	24
Oven Light Bulb Removal.....	25
Side Lights	25
Top Light	25
Temperature Sensor (RTD) Removal	26
Broil Element Removal	27
Glass Enclosed.....	27
Tubular Style.....	27
Bake Element Removal	28
Catalyst Removal.....	28
Convection Baffle Removal.....	29
Convection Bake Element Removal.....	29
Convection Fan Motor Removal.....	30
Convection Fan Blade Removal	30
Access to Control Components.....	31
Partial Access.....	31

Full Access	31
Oven Function Selector Removal	32
Oven Thermostat Removal.....	32
Oven Control Board Removal.....	33
Oven Light Switch Removal.....	33
Oven Cycle/Clean Indicator Lights Removal	34
Oven Timer/Clock Removal	34
Digital Timer	34
Analog Timer	35
Convection Motor Capacitors Removal.....	36
Thermal Cut-Out (TCO) Removal	37
Single Oven and Upper Double Oven.....	37
Lower Double Oven	37
Door Latch Assembly Removal	38
Single Oven and Upper Double Oven.....	38
Lower Double Oven	38
Door Switch Removal	39
Single Oven and Upper Double Oven.....	39
Lower Double Oven	40
Oven Lights Transformer	40
Blower Motor	41
Single Oven and Upper Double Oven.....	41
Lower Double Oven	42
Door Hinge Receiver Removal	43
Meat Probe Socket Removal	43
Troubleshooting	44
Selector and Thermostat Characteristics	44
Component Testing	45
Troubleshooting Guide.....	47
Oven Control Board	50
Communication between Control Boards on Double Ovens	52
Strip Circuits and Schematics	53

Wiring Schematics – 12 Volt Lighting

Professional Select Single Oven - VESO127 – VESO130	56
Professional Premiere Single Oven – VESO527 – VESO530	57
Professional Select Double Oven (<i>Upper</i>) - VEDO127 – VEDO130	58
Professional Select Double Oven (<i>Lower</i>) - VEDO127 – VEDO130	59
Professional Premiere Double Oven (<i>Upper</i>) – VEDO527 – VEDO530	60
Professional Select Double Oven (<i>Lower</i>) – VEDO527 – VEDO530	61
Designer Select Single Oven - DESO127 – DESO130	62
Designer Premiere Single Oven – DESO527 – DESO530	63
Designer Select Double Oven (<i>Upper</i>) - DEDO127 – DEDO130	64
Designer Select Double Oven (<i>Lower</i>) - DEDO127 – DEDO130	65
Designer Premiere Double Oven (<i>Upper</i>) – DEDO527 – DEDO530	66
Designer Premiere Double Oven (<i>Lower</i>) – DEDO527 – DEDO530	67

Wiring Schematics – 120 Volt Lighting

Service Bulletin – TC0019A-SP -	68
Changes in Board design (Original to current)	69

Professional Series

VESO

Professional Select Single Oven (REV A) - VESO127 – VESO130	70
Professional Select Single Oven (REV B) - VESO127 – VESO130	71
Professional Premiere Single Oven (REV A) - VESO527 – VESO530	72
Professional Premiere Single Oven (REV B) - VESO527 – VESO530	73

VEDO

Professional Select Double Oven (REV A) (<i>Upper</i>) - VEDO127 – VEDO130	74
Professional Select Double Oven (REV A) (<i>Lower</i>) - VEDO127 – VEDO130	75
Professional Select Double Oven (REV B) (<i>Upper</i>) - VEDO127 – VEDO130	76
Professional Select Double Oven (REV B) (<i>Lower</i>) - VEDO127 – VEDO130	77
Professional Premiere Double Oven (REV A) (<i>Upper</i>) – VEDO527 – VEDO530	78
Professional Premiere Double Oven (REV A) (<i>Lower</i>) – VEDO527 – VEDO530	79
Professional Premiere Double Oven (REV B) (<i>Upper</i>) – VEDO527 – VEDO530	80
Professional Premiere Double Oven (REV B) (<i>Lower</i>) – VEDO527 – VEDO530	81

Designer Series

DESO

Designer Select Single Oven (REV A) - DESO127 – DESO130	82
Designer Select Single Oven (REV B) - DESO127 – DESO130	83
Designer Premiere Single Oven (REV A) - DESO527 – DESO530	84
Designer Premiere Single Oven (REV B) - DESO527 – DESO530	85

DEDO

Designer Select Double Oven (REV A) (<i>Upper</i>) - DEDO127 – DEDO130	86
Designer Select Double Oven (REV A) (<i>Lower</i>) - DEDO127 – DEDO130	87
Designer Select Double Oven (REV B) (<i>Upper</i>) - DEDO127 – DEDO130	88
Designer Select Double Oven (REV B) (<i>Lower</i>) - DEDO127 – DEDO130	89
Designer Premiere Double Oven (REV A) (<i>Upper</i>) – DEDO527 – VEDO530	90
Designer Premiere Double Oven (REV A) (<i>Lower</i>) – VEDO527 – VEDO530	91
Designer Premiere Double Oven (REV B) (<i>Upper</i>) – VEDO527 – VEDO530	92
Designer Premiere Double Oven (REV B) (<i>Lower</i>) – VEDO527 – VEDO530	93



General Overview

The Viking Built-In Electric Wall Ovens are available in various configurations. The oven features include hidden bake elements, two broil element styles (glass enclosed or tubular), TruConvec™ convection motor and bake element, and two types of oven controls. The ovens are available in single or double oven configurations and come in two widths.

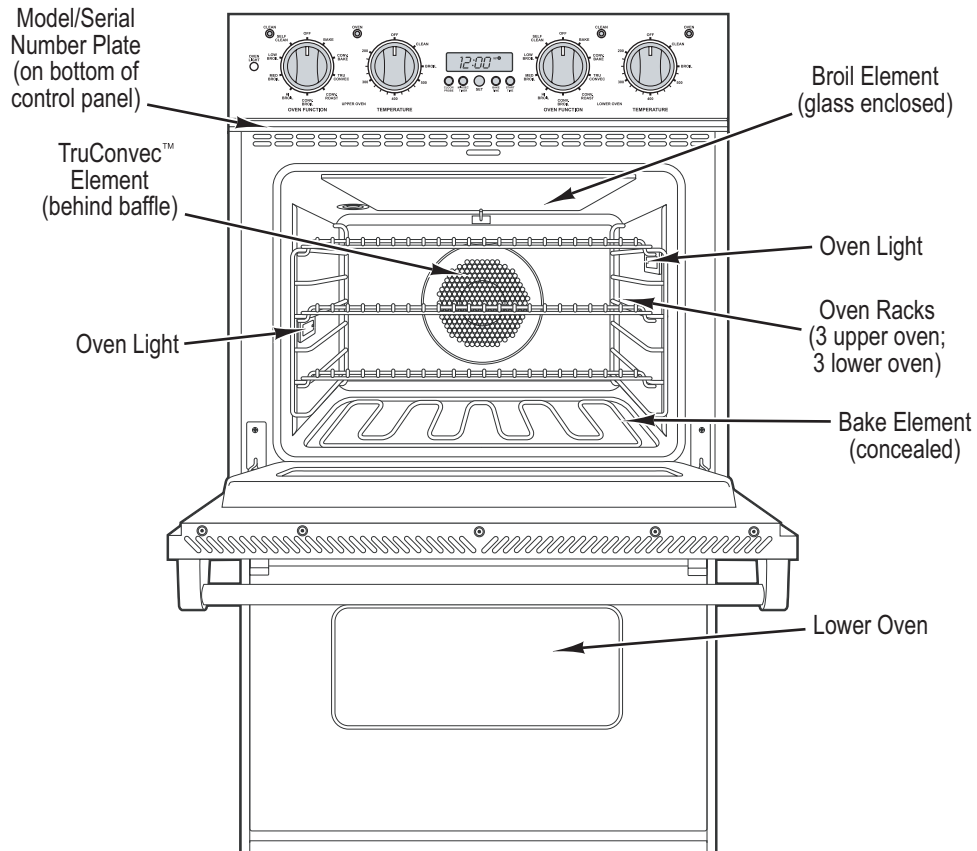

Professional Premiere Double Oven Shown



Specifications

Professional Knobs	Select				Premiere			
	27" Wide		30" Wide		27" Wide		30" Wide	
Model Number	VESO127	VEDO127	VESO130	VEDO130	VESO527	VEDO527	VESO530	VEDO530
Clock	Digital				Digital			
Bake Element	10-Pass Concealed Element				10-Pass Concealed Element			
Broiler	10-Pass Tubular				Electric Infrared Glass Enclosed			
Convection System	2-Speed	2-Speed (upper only)	2-Speed	2-Speed (upper only)	2-Speed	2-Speed (both ovens)	2-Speed	2-Speed (both ovens)
Oven Light	One	One	One	One	Three	Three	Three	Three
Meat Probe	No	No	No	No	Yes	Yes	Yes	Yes
Electrical Requirements	4-Wire w/ground, 30 Amp. Connection	4-Wire w/ground, 50 Amp. Connection	4-Wire w/ground, 30 Amp. Connection	4-Wire w/ground, 50 Amp. Connection	4-Wire w/ground, 30 Amp. Connection	4-Wire w/ground, 50 Amp. Connection	4-Wire w/ground, 30 Amp. Connection	4-Wire w/ground, 50 Amp. Connection
Max Amp. Usage	24	40	24	40	24	40	24	40
Bake Rating	3000 Watts				3000 Watts			
Broil Rating	4000 Watts				3500 Watts			
TruConvec Rating	3000 Watts				3000 Watts			

Designer Knobs	Select				Premiere			
	27" Wide		30" Wide		27" Wide		30" Wide	
Model Number	DESO127	DEDO127	DESO130	DEDO130	DESO527	DEDO527	DESO530	DEDO530
Clock	Digital				Digital			
Bake Element	10-Pass Concealed Element				10-Pass Concealed Element			
Broiler	10-Pass Tubular				Electric Infrared Glass Enclosed			
Convection System	2-Speed	2-Speed (upper only)	2-Speed	2-Speed (upper only)	2-Speed	2-Speed (both ovens)	2-Speed	2-Speed (both ovens)
Oven Light	One	One	One	One	Three	Three	Three	Three
Meat Probe	No	No	No	No	Yes	Yes	Yes	Yes
Electrical Requirements	4-Wire w/ground, 30 Amp. Connection	4-Wire w/ground, 50 Amp. Connection	4-Wire w/ground, 30 Amp. Connection	4-Wire w/ground, 50 Amp. Connection	4-Wire w/ground, 30 Amp. Connection	4-Wire w/ground, 50 Amp. Connection	4-Wire w/ground, 30 Amp. Connection	4-Wire w/ground, 50 Amp. Connection
Max Amp. Usage	24	40	24	40	24	40	24	40
Bake Rating	3000 Watts				3000 Watts			
Broil Rating	4000 Watts				3500 Watts			
TruConvec Rating	3000 Watts				3000 Watts			



Serial Number Location

The model number and serial number are located on the data plate. The data plate is located on the top left side of the oven cavity under the control panel.

Model Numbers

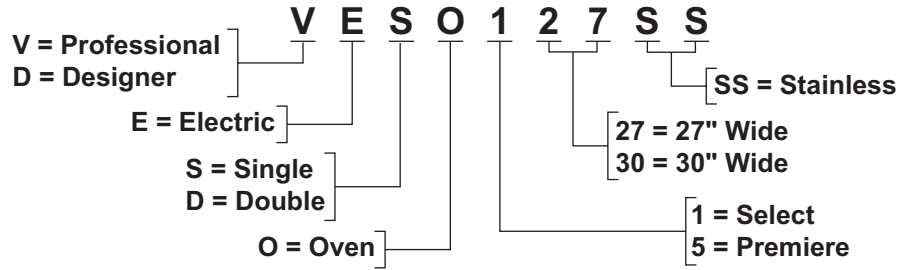

Serial Numbers

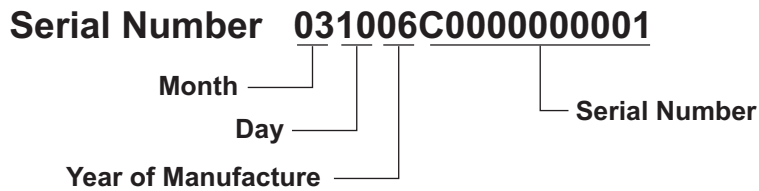

Operation

Oven Control Panel

The Viking Built-In Electric Wall Ovens are available in two control panel options. Each oven has a Function Selector and a Temperature Control. On double ovens, the Interior Oven Light Switch and Electronic Timing Center are shared.

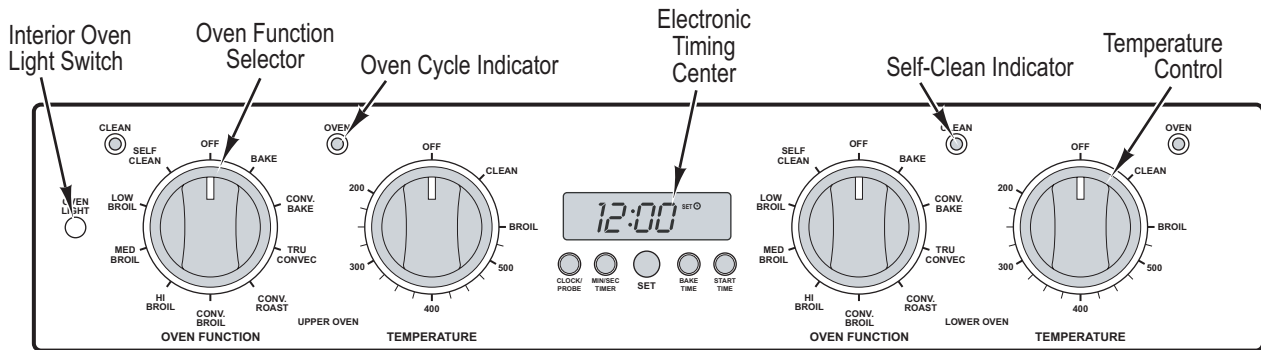

(Professional Models)

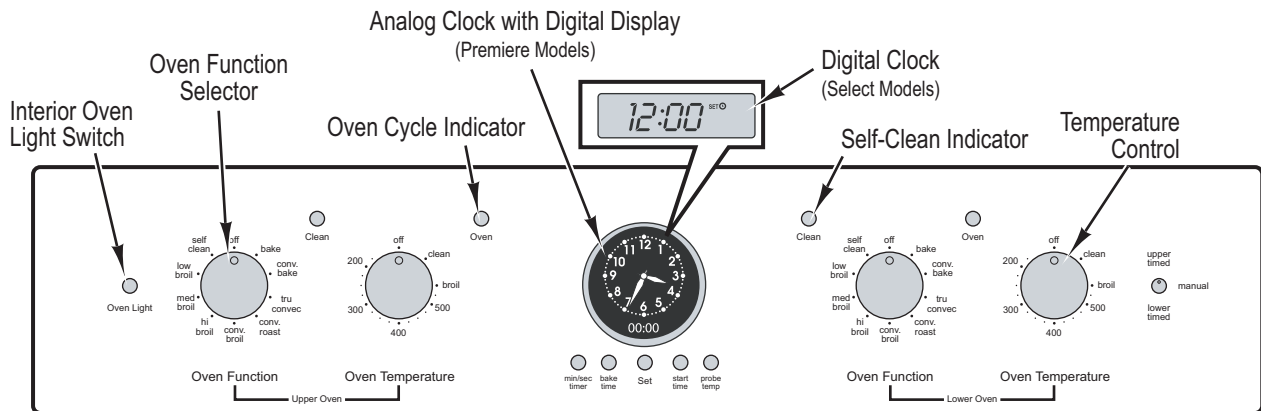

(Designer Models)



Oven Preheat Chart

Preheat is defined as the time from room temperature till the oven light cycles off. The following chart represents a typical preheat cycle set at 300° F. The chart shows what elements are on and in what order. The numbered columns represent the number of cycles the oven takes to complete preheat. All elements use approximately 240V and cycle on and off for different lengths of time. Cycles for double ovens may vary.

Cycle	Inner broil	Outer broil	Inner bake	Outer bake	Oven indicator light on
1.	X	X		X	X
2.	X	X	X		X
3.		X		X	X
4.	X	X		X	X
5.	X	X	X		X
6.		X		X	X
7.	X	X		X	X
8.	X	X	X		X
9.		X		X	X
10.	X	X		X	X
11.	X	X	X		X
12.		X		X	X
13.	X	X		X	X
14.	X	X	X		X
15.		X		X	X
16.		X	X	X	X
17.	X		X	X	X
18.	X		X		X
19.		X		X	X
20.		X	X	X	X
21.	X		X	X	X
22.	X		X		X
23.		X		X	X
24.		X	X	X	X
25.	X		X	X	X
26.	X		X		X
27.		X		X	X
28.		X	X	X	X
29.				X	X
30.		X			X
31.			X		X
32.	Oven light cycles off. Preheat completed, all elements off until regular cycling takes over.				

Oven Settings and Functions

Self-Clean

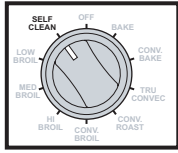

During the self-clean cycle, the oven reaches elevated temperatures using the broil and bake elements. The broil elements use approximately 240V and remain on during the self-clean cycle. The bake elements use approximately 240V and cycle on for a few seconds at various times during the cleaning process.

High Broil

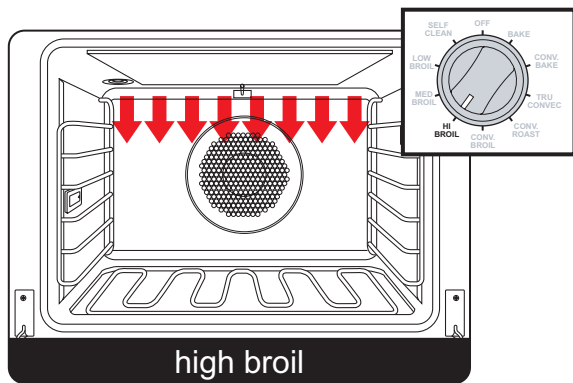

Heat radiates from both broil elements. The broil elements use approximately 240V and remain on constantly.

Medium Broil

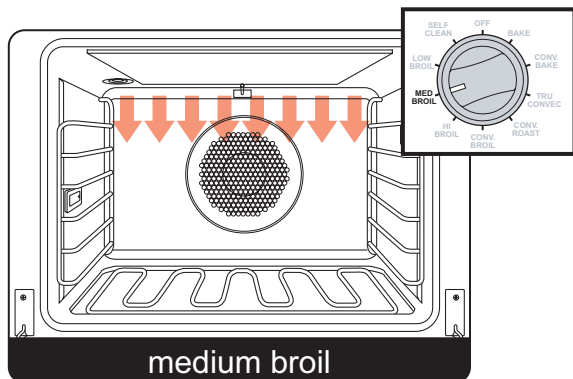

Heat radiates from both broil elements. The broil elements use approximately 240V and pulse on for 40 seconds and off for 15 seconds.

Low Broil

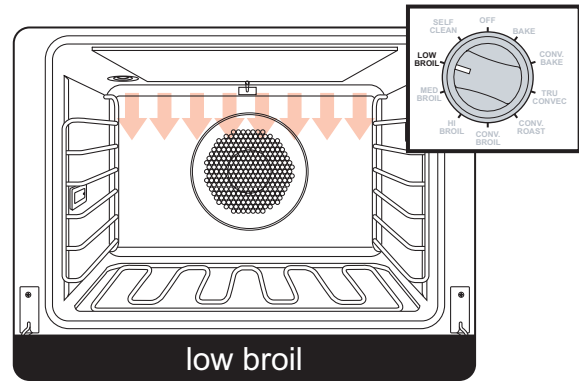

Heat radiates only from the inner broil element. The inner broil element uses approximately 240V and pulses on for 25 seconds and off for 35 seconds.

Convection Broil

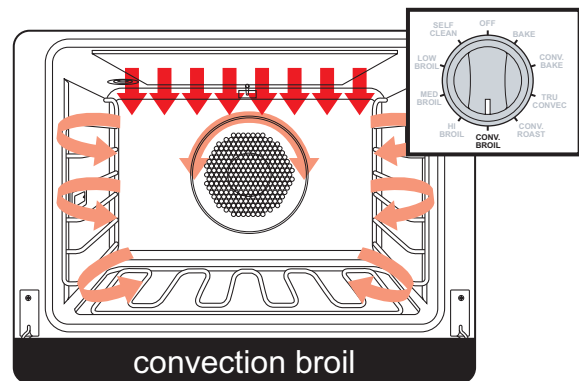

Heat radiates from both broil elements. The broil elements use approximately 240V and pulse on for 53 seconds and off for 7 seconds. Additionally, the convection fan cycles on for 40 seconds, cycles off for 7 seconds, and then cycles on in the opposite direction for 40 seconds. This cycle then repeats.

Convection Defrost

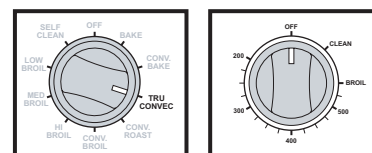

Only the convection fan operates. No elements are on. The convection fan cycles on in one direction for 40 seconds, cycles off for 7 seconds, and then cycles on in the opposite direction for 40 seconds. This cycle then repeats.

Convection Dehydrate

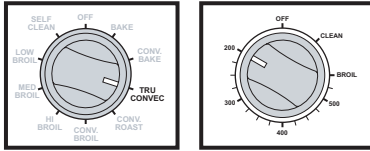

With the selector set to TruConvec and the temperature control on 200° F, warm air is circulated by the convection fan.

Two-Element Bake

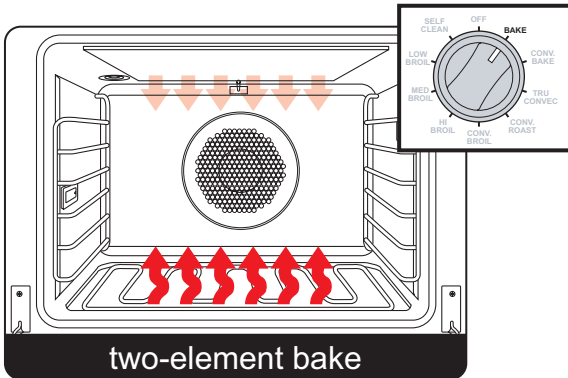

The bake elements use approximately 240V and the inner broil element cycles on and off at various times to maintain the set temperature. See the oven preheat chart for more information.

TruConvec

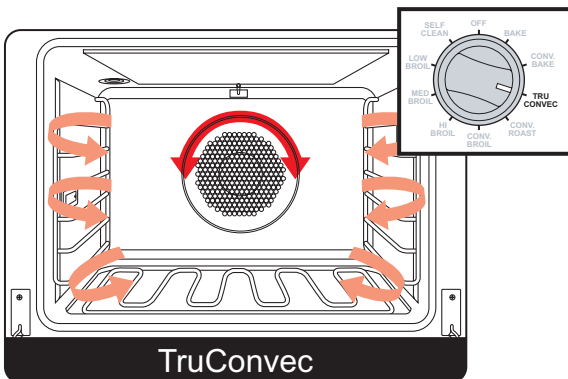

The convection element uses approximately 240V and pulses on for 53 seconds and off for 7 seconds. The convection fan remains in low speed, changing direction every 40 seconds.

Convection Bake

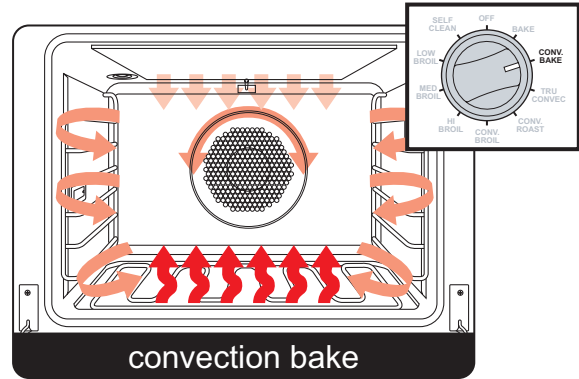

The convection element uses approximately 240V and cycles on and off at various times. The bake and broil elements use 240V and pulse on and off less frequently than the convection element. Additionally, the convection fan cycles on for 40 seconds, cycles off for 7 seconds, and then cycles on in the opposite direction for 40 seconds. This cycle then repeats.

Convection Roast

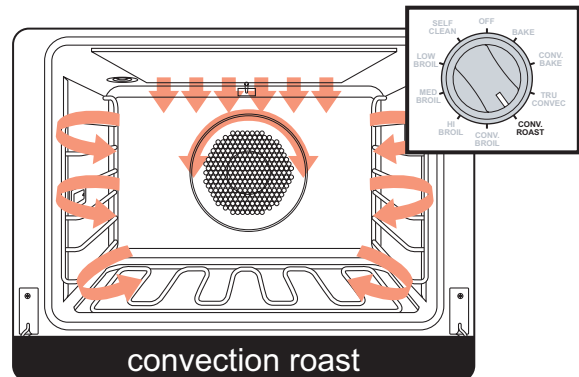

The convection element uses approximately 240V and pulses on for 40 seconds and off for 7 seconds. The convection fan remains in high speed, changing direction every 40 seconds. During the change in direction, the broil elements pulse on for approximately 2 seconds.

Clock and Timers

Digital Electronic Timing Center

The Electronic Timing Center is used to program and control all timing functions. It has five display and programming modes that are activated by the four push buttons and the “SET” knob. Both the Bake Time mode and the Min/Sec Timer mode can be used to time cooking periods. These features can be used at the same time when both ovens are in use. Only the Bake Time and Self-Cleaning modes shut the oven off automatically when the timed program is over. One oven can also be cleaned while timing foods in the other oven using the Min/Sec Timer mode.

Setting the Time of Day

The time of day must be set before any other program can be used. When the oven is first connected to the power, the timer display will show --:--.



To program the time of day:

1. Press the “CLOCK/PROBE” * button once. 12:00 will be displayed with the word SET in the upper right corner.
2. Turn the “SET” knob until the correct time of day is displayed. AM and PM are not indicated.
3. Press the “CLOCK/PROBE” button again. The word SET will disappear and the correct time is now set into the timer.

The time of day cannot be changed while there is a Bake Time or Start Time cycle programmed into the timer.

Setting the Min/Sec Timer

The Min/Sec Timer is designed for accurate timing and can be used at the same time the Bake Time or Start Time functions are in use. It can be used for timing up to 24 hours. When setting the timer, the time displayed will increase in 1 minute increments. When the timer counts down to 1 minute, the timer alarm will give two short beeps and the display changes from hours:minutes to seconds only.

To program the Min/Sec Timer:

1. Press the “MIN/SEC TIMER” button. The timer will display :00 and the word TIMER will be displayed in the lower right corner.
2. Turn the “SET” knob until the desired duration time is displayed.

The Min/Sec Timer is now programmed. An alarm will sound at the end of the countdown. The program can be canceled anytime by setting the remaining time to 00:00. To change back to the time of day, press the “CLOCK/PROBE” button. Notice that a small clock will be displayed in the upper right corner to indicate that a program is in progress. The display will return automatically to the Min/Sec Timer after a few seconds.

Timer Alarm

At the end of a Min/Sec Timer program or Bake Time program, the alarm will consist of three beeps, followed by two beeps every 10 seconds, until the “MIN/SEC TIMER” button is pressed. Whenever a valid function key is pressed or when a control function starts automatically, one beep will be sounded. When an invalid function key is pressed, two beeps will be sounded.



Setting the Automatic Start Time Bake Program

The Bake Time and Start Time modes of the timer can be used to automatically turn the oven on and off at a preselected time.



To set the Automatic Time Bake Program:

1. Set the start time:

For Single Ovens – Program the start time by pressing the “START TIME” button and turning the “SET” knob until the desired start time is displayed. This is the time of day you want the food to begin cooking.

For Double Ovens – Press the “START TIME” button once to set the starting time for the upper oven (UPPER OVEN will show on the display). Press the “START TIME” button twice to set the starting time for the lower oven (LOWER OVEN will show on the display). Then, program the start time by turning the “SET” knob until the desired start time is displayed. This is the time of day you want the food to begin cooking.

2. Set the desired baking time:

Once the start time is set, the display will switch to :00 and the words SET, COOK, and TIME will appear on the right side of the display. You will now enter the desired baking time. Turn the “SET” knob until the desired baking time is displayed in hours and minutes. Once the desired bake time is set, the word SET will disappear and the word DELAY will appear in

the display indicating that the Bake Time program has been set.

NOTE

For Double Ovens, the word DELAY will show with either UPPER OVEN or LOWER OVEN, depending on which oven has been selected.

3. Set the Oven Function selector to the desired function –BAKE, CONVECTION BAKE, OR TRUCONVEC, etc.
4. Set the temperature control knob to the desired baking temperature. The automatic time bake program is now set.

NOTE

The display will continue to show the amount of bake time that was programmed (this will remain until the programmed start time is reached). You can return the display to clock mode by pressing the “CLOCK/PROBE” button – Notice that a small clock will be displayed in the upper right corner to indicate that a program is in progress. Switch back to the timer mode by pressing the “BAKE TIME” button.

5. When the specified time is reached, the oven will automatically turn on. It will bake for the programmed amount of time at the selected temperature.

NOTE

Setting the remaining duration time to :00 will cancel the Automatic Bake program. At one minute from the end of the specified bake program, the oven timer will beep once. At the end of the specified bake program, the oven will automatically turn off and the timer will sound a series of three beeps.

6. Press the “START TIME” button to end the program. The display will then return to displaying the time.
7. Turn the temperature control knob and oven function selector to off.

Setting the Analog Display

The time-of-day must be set before any other program can be used. When the oven is first connected to the power, the digital display will show 00:00.

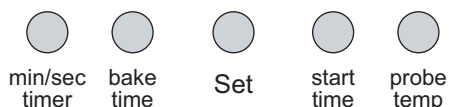

To program the time-of-day:

1. Push and hold the “min/sec timer” and “bake time” buttons at the same time.
2. Turn the “Set” knob until correct time is displayed on the digital clock.
3. Release the buttons.

The analog clock will automatically set after the digital time is set.

Setting the Min/Sec Timer

The Min/Sec Timer is designed for accurate timing and can be used at the same time the Bake Time or Start Time functions are in use. It can be used for timing up to 24 hours.

To program the Min/SecTimer

4. Push and release the “min/sec timer” button.
5. Rotate “Set” knob until desired duration of time is displayed. Timer starts seconds after “Set” knob stops rotating. A tone indicates the timer has started.

When the timer has one minute remaining, the timer will sound twice and begin to countdown by seconds. A tone will sound three times indicating the time is complete and twice every ten seconds after completion until timer function is cleared.

NOTE

Press any function button to clear a completed cycle or function.

Setting the Bake Time Program

The Bake Time program is used for controlled timing of baked or roasted foods. At the end of the timed cycle, the oven automatically turns off.

Setting the Automatic Start Time Bake Program

The Bake Time program is used for controlled timing of baked or roasted foods. At the end of the timed cycle, the oven automatically turns off.

To Set the Bake Time Program

1. Turn the “manual” knob to “upper timed” or “lower timed” position, depending upon the oven mode and oven being used.
2. Set the Oven Function Selector to the BAKE, CONVECTION BAKE, or TRUCONVEC position, depending upon the type of baking being used.
3. Set the temperature control knob to the desired temperature and allow for preheating.
4. Press and release the “bake time” button. The timer will display :00 with the words SET and COOK in the upper right corner of the digital display.
5. Turn the “Set” knob until the desired baking time is displayed in hours and minutes. The cook time/remaining time and the word COOK will be displayed.

The word COOK will flash and the tone will sound three times when the time is completed; oven will turn off. The tone will sound twice every ten seconds after completion until timer function is cleared.

6. Turn off the oven.

To set the Automatic Time Bake Program

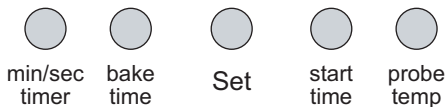

1. Set the start time:
 - a. For Single Ovens – Program the start time by pressing the “start time” button and turning the “Set” knob until the desired start time is displayed. This is the time of day you want the food to begin cooking.
 - b. For Double Ovens – Press the “start time” button once to set the starting time for the upper oven (UPPER OVEN will show on the display). Press the “start time” button twice to set the starting time for the lower oven (LOWER OVEN will show on the display). Then, program the start time by turning the “Set” knob until the desired start time is displayed. This is the time of day you want the food to begin cooking.

2. Set the desired baking time:

Once the start time is set, the display will switch to :00 and the words SET, COOK, and TIME will appear on the right side of the display. You will now enter the desired baking time. Turn the “Set” knob until the desired baking time is displayed in hours and minutes. Once the desired bake time is set, the word SET will disappear and the word DELAY will appear in the display indicating that the Bake Time program has been set.

NOTE

For Double Ovens, the word DELAY will show with either UPPER OVEN or LOWER OVEN, depending on which oven has been selected.

3. Set the Oven Function selector to the desired function – BAKE, CONVECTION BAKE, OR TRUCONVEC, etc.
4. Set the temperature control knob to the desired baking temperature.
5. The automatic time bake program is now set.

NOTE

The display will continue to show the amount of bake time that was programmed (this will remain until the programmed start time is reached). You can return the display to clock mode by pressing the “probe/temp” button – Notice that a small clock will be displayed in the upper right corner to indicate that a program is in progress. Switch back to the timer mode by pressing the “bake time” button.

6. When the specified time is reached, the oven will automatically turn on. It will bake for the programmed amount of time at the selected temperature.

NOTE

At one minute from the end of the specified bake program, the oven timer will beep once. At the end of the specified bake program, the oven will automatically turn off and the timer will sound a series of three beeps. This will continue until the “start time” button is pressed. The display will then return to displaying the time.

NOTE

Setting the remaining duration time to :00 will cancel the Automatic Bake program.

Self-Clean Cycle

This oven features an automatic pyrolytic self-cleaning cycle. During this cycle, the oven reaches elevated temperatures in order to burn off soil and deposits. An integral smoke eliminator helps reduce odors associated with the soil burn-off. A powder ash residue is left in the bottom of the oven after completion of the Self-Clean cycle. The door latch is automatically activated after selecting the Self-Clean setting. The latch ensures that the door cannot be opened while the oven interior is at clean temperatures.

Before starting the Self-Clean cycle:

1. Remove the oven racks and any other items/utensils from the oven. The high heat generated during the cleaning cycle can discolor, warp, and damage these items. Do not use foil or liners in the oven. During the Self-Clean cycle, foil can burn or melt and damage the oven surface.
2. Wipe off any large spills from the oven bottom and sides. Never use oven cleaners inside a self-cleaning oven or on raised portions of the door.
3. Some areas of the oven must be cleaned by hand before the cycle begins. Soils in these areas will be baked on and very difficult to clean if not removed first. Clean the door up to the gasket, the door frame, and up to 2 inches inside the frame with detergent and hot water. Rinse thoroughly and dry.

To start the Self-Clean cycle:

1. Close the door completely.
2. Turn the oven selector knob to self-clean.
3. Turn the temperature control knob to clean. The clean indicator light will come on. Within 30 seconds, the automatic door latch engages and the oven indicator light comes on. The oven indicator light will remain on until the oven reaches the self-clean temperature and will then cycle on and off during the self-clean cycle.

4. The clean indicator light will remain on until the self-clean is completed or interrupted and the oven temperature drops to a safe temperature. A complete cycle is approximately 3 1/2 hours with an additional 30 minutes needed for the oven to cool down enough for the door latch to disengage.

NOTE

A fan noise will be heard during the self-clean cycle and will continue to run for the 3 1/2 hour duration of the self-clean cycle.

5. When the cycle is completed, turn the oven selector and temperature control knob to the off position. When the oven has completely cooled, open door and remove any ash from the oven surfaces with a damp cloth.

To stop the Self-Clean cycle:

To cancel or interrupt the self-cleaning cycle, turn the temperature control knob and the oven function selector knob to OFF. When the oven temperature drops to a safe temperature, the automatic door latch will release and the oven door can be opened. When the oven has completely cooled, remove any ash from the oven surfaces with a damp sponge or cloth.

Service Procedures

Part Locator

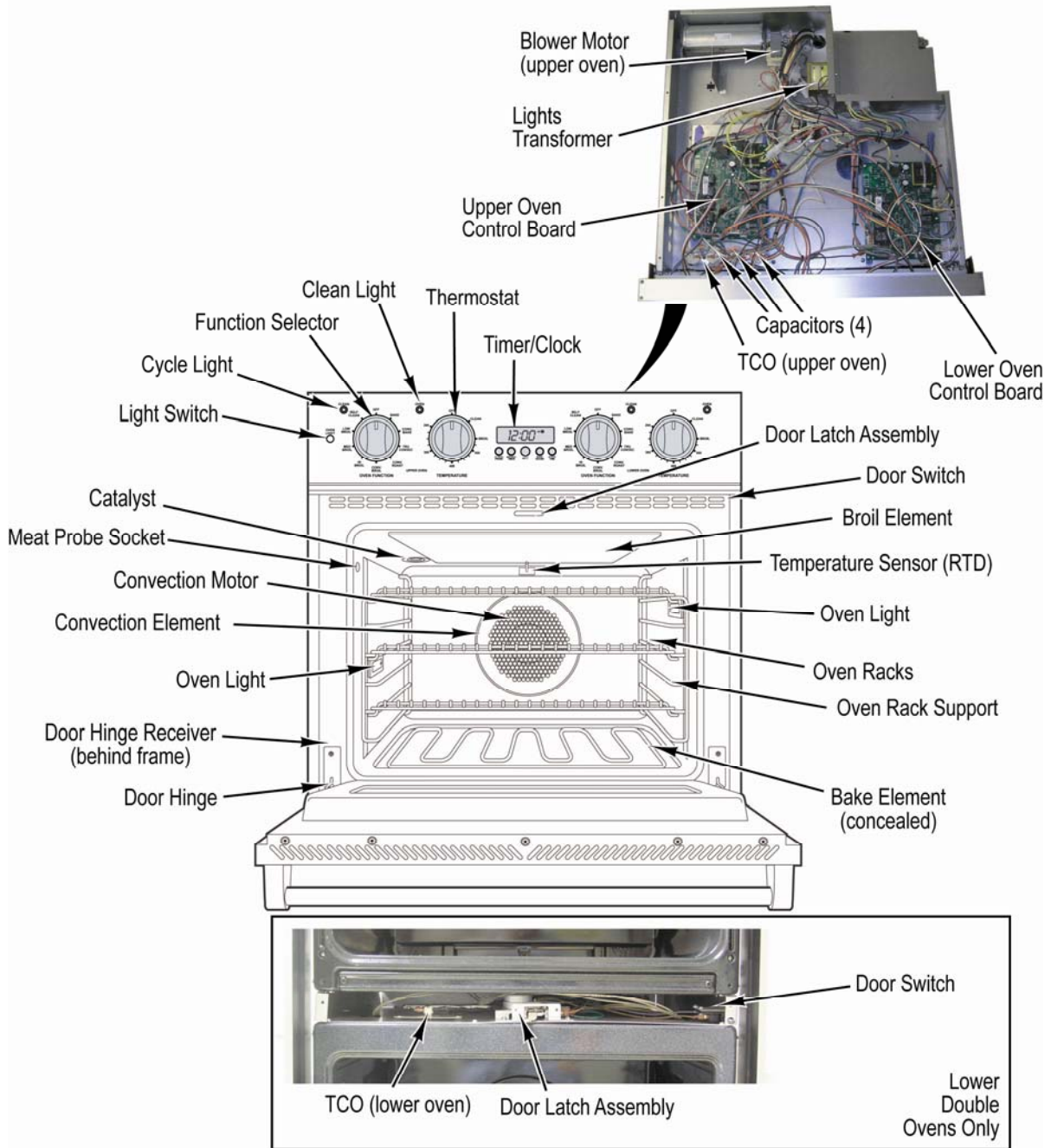

Service Situation Chart

TASK	Single Unit	Double Unit	Front Serviceable	Partial Removal Required	Full Removal Required
Door Assembly	X	X	X		
Inner Door Glass	X	X	X		
Outer Door Glass	X	X	X		
Door Hinge	X	X	X		
Door Handle	X	X	X		
Door Gasket	X	X	X		
Oven Racks	X	X	X		
Oven Rack Supports	X	X	X		
Oven Temperature Sensor	X	X	X		
Broil Elements	X	X	X		
Bake Elements	X	X	X		
Convection Bake Elements	X	X	X		
Convection Motor Assembly	X	X	X		
Oven Light Bulbs	X	X	X		
Oven Catalyst (Smoke Elim.)	X	X	X		
Oven Function Selector	X	X		X	
Oven Thermostat	X	X		X	
Oven Control Board	X	X		X	
Oven Light Switch	X	X		X	
Oven Cycle/Clean Light	X	X		X	
Oven Timer/Clock	X	X		X	
Capacitors	X	X		X	
Door Latch Assembly (Upper)	X	X		X	
Door Latch Assembly (Lower)		X	X		
Door Switch (Upper)	X	X		X	
Door Switch (Lower)		X		X	
Lights Transformer	X	X			X
Blower Motor (Upper)	X	X			X
Blower Motor (Lower)		X			X
TCO (Upper)	X	X		X	
TCO (Lower)		X	X		
Door Hinge Receiver	X	X			X
Meat Probe Socket	X	X			X

Partial Oven Removal

WARNING: Disconnect power to oven before servicing. Follow lockout/tagout procedures.

CAUTION: The oven is heavy. Use care when sliding oven out to avoid damaging the oven, wall, or cabinet.

Condition Requirements:

Door Assembly Removed

Oven Racks Removed

1. Remove two screws (single oven) or four screws (double oven) that attach the side of the outer trim to the wall or cabinet.

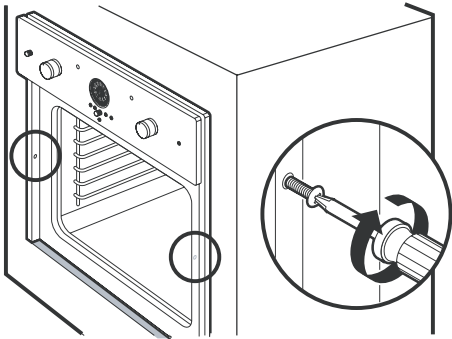

2. Slide the oven forward.

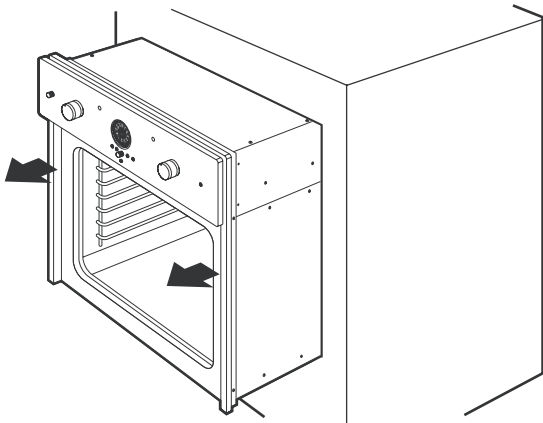

NOTE

If the oven is advanced past the balance point, use appropriate bracing under the front of the oven to avoid excessive tipping.

3. Reverse procedure for installation.

Full Oven Removal

CAUTION: The oven is heavy. Removal from the installation will require two people. Use care when removing the oven to avoid damaging the oven, wall, cabinet, or floor.

Condition Requirements:

Oven Partially Removed

1. Continue to slide oven from the installation and place it on a protected surface.

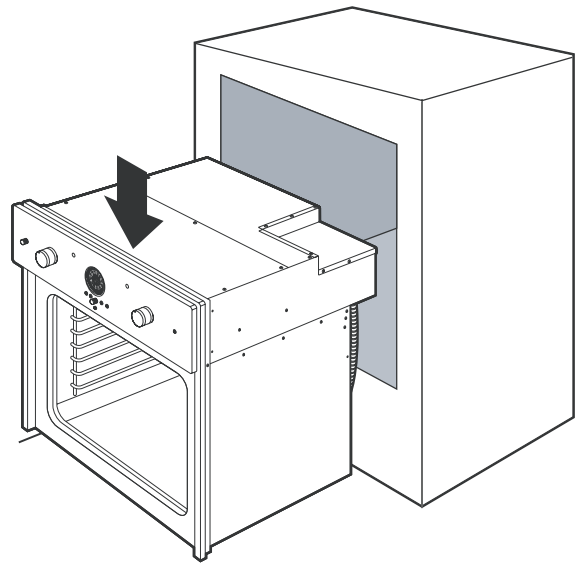

2. Reverse procedure for installation.

Door Assembly Removal

CAUTION: Use care when handling the door assembly. Do not lift or carry the door by the handle.

Condition Requirements:

Door Lowered

1. Place pin in pin hole.
2. Remove screw and hinge trim from oven.

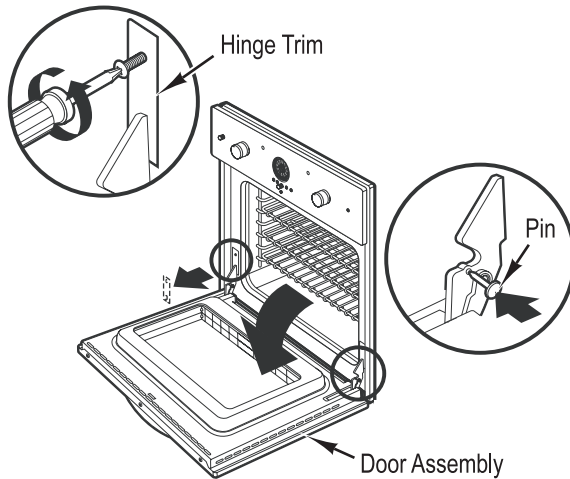

3. Close door until pins stop door.
4. Lift door up and out.

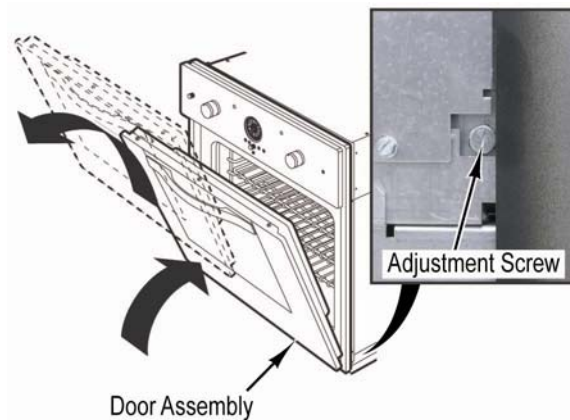

NOTE

To adjust the door, turn the adjustment screw clockwise to raise the door or turn it counterclockwise to lower the door. The oven must be partially removed to adjust the door.

5. Reverse procedure for installation.

Door Gasket Removal

Condition Requirements:

Door Lowered

1. Insert a narrow tool or small flat-blade screwdriver into the center of each clip and pry upward.
2. Remove the door gasket from two holes in the bottom of the door liner.

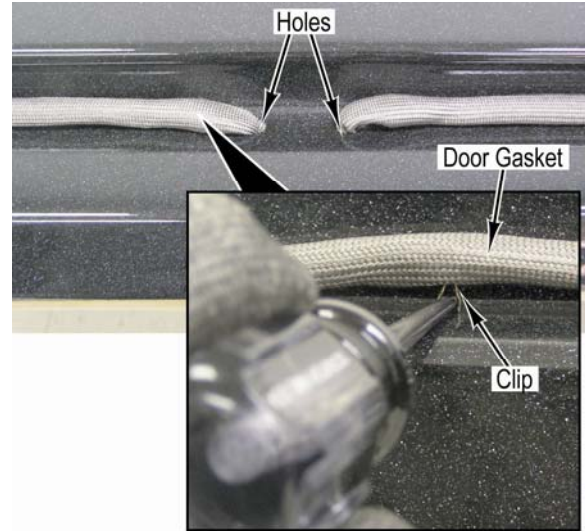

3. Reverse procedure for installation.

Outer Door Panel Removal

CAUTION: Use care when handling the door assembly. Do not lift or carry the door by the handle.

Condition Requirements:

Door Assembly Removed

1. Place the door handle side down on a protected surface.
2. Remove seven screws that attach the outer door panel to the door liner.



3. Turn the door over and lift the outer door panel from the door liner.



4. Reverse procedure for installation.

Outer Door Glass Removal

Condition Requirements:

Outer Door Panel Removed

1. Remove four screws that attach the outer door glass assembly to the heat barrier.
2. Remove the outer door glass from the heat barrier.

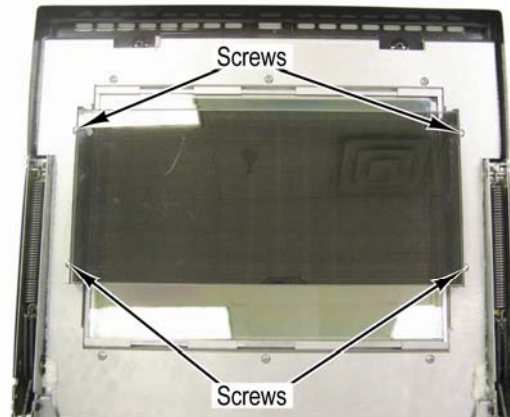

3. Reverse procedure for installation.

Inner Door Glass Removal

Condition Requirements:

Outer Door Glass Removed

1. Remove six screws that attach the heat barrier to the door liner.
2. Lift the heat barrier from the door liner.

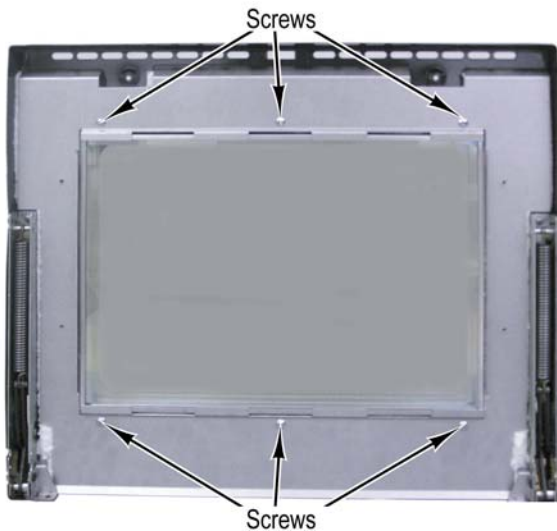

3. Lift the inner door glass from the door liner.



4. Reverse procedure for installation.

Door Handle Removal

CAUTION: Use care when handling the door assembly. Do not lift or carry the door by the handle.

Condition Requirements:

Outer Door Panel Removed

1. Remove four 3/8 inch bolts that hold the door handle to the outer panel.
2. Remove the door handle from the outer panel.

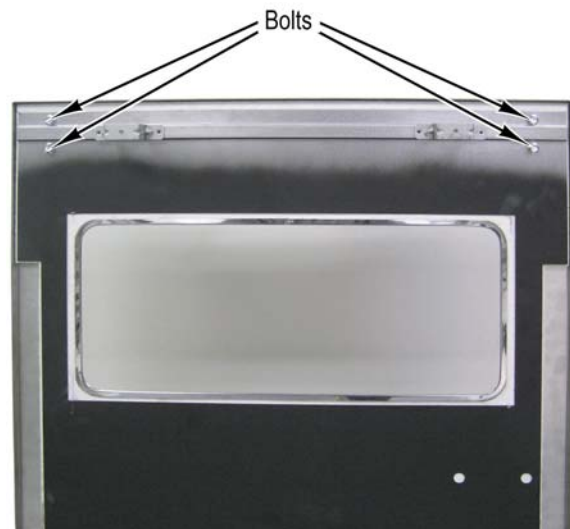

3. Reverse procedure for installation.

Door Hinge Removal

Condition Requirements:

Outer Door Panel Removed

1. Remove four screws that attach the hinge to the door liner.
2. Remove the hinge from the door liner.

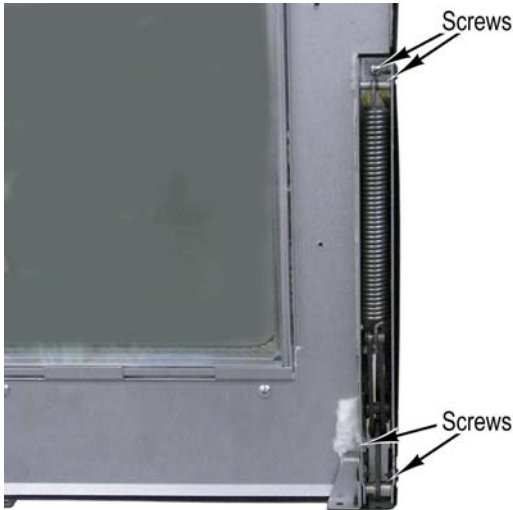

3. Reverse procedure for installation.

Oven Rack Removal

Glide Rack

Condition Requirements:

Door Lowered

1. Lift the glide rack off of the rack supports.

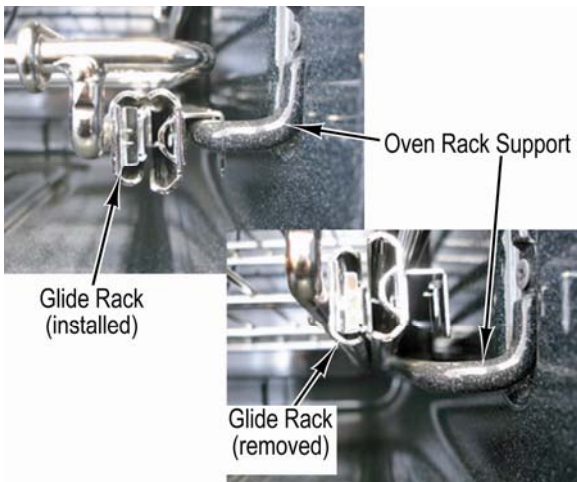

2. Reverse procedure for installation.

Standard Rack

Condition Requirements:

Door Lowered

1. Slide the oven rack forward and then lift the front end to remove the rack from the rack supports.
2. Reverse procedure for installation.

Oven Rack Support Removal

Condition Requirements:

Oven Racks Removed

1. Remove four screws from each oven rack support.

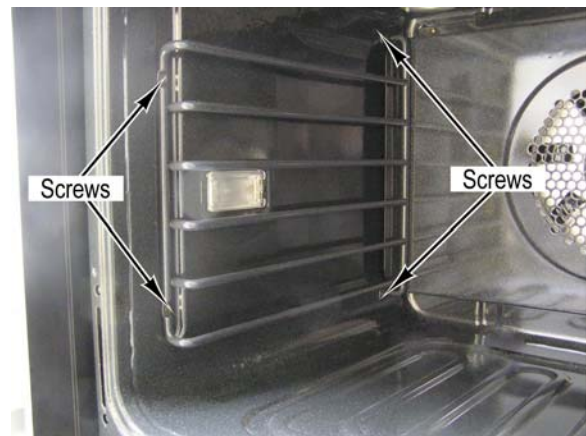

2. Reverse procedure for installation.

Oven Light Bulb Removal

Side Lights

The side light bulbs are located in the oven cavity and use a 5W bulb.

WARNING: Disconnect power to oven before servicing. Follow lockout/tagout procedures.

CAUTION: Do not touch bulb with bare hands. Clean off any signs of oil from the bulb and handle with a soft cloth.

Condition Requirements:

Door Lowered

1. Unsnap the glass cover at the opposite end from the metal hinge.
2. Firmly grasp the bulb and pull out.

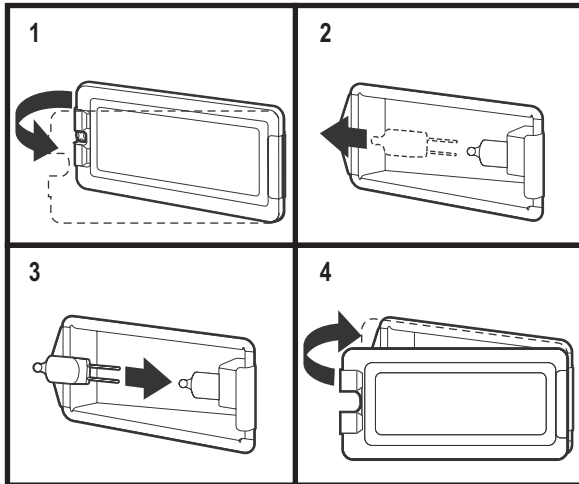

3. Replace with a 64405, 12V-5W bulb.
4. Replace the light cover by first sliding it into the metal hinge and then snapping closed on opposite end.

Top Light

The top light bulb is located in the cavity and uses a 20W bulb.

WARNING: Disconnect power to oven before servicing. Follow lockout/tagout procedures.

CAUTION: Do not touch bulb with bare hands. Clean off any signs of oil from the bulb and handle with a soft cloth.

Condition Requirements:

Door Lowered

5. Carefully pry the glass cover on both sides until it releases.
6. Firmly grasp the bulb and pull out.

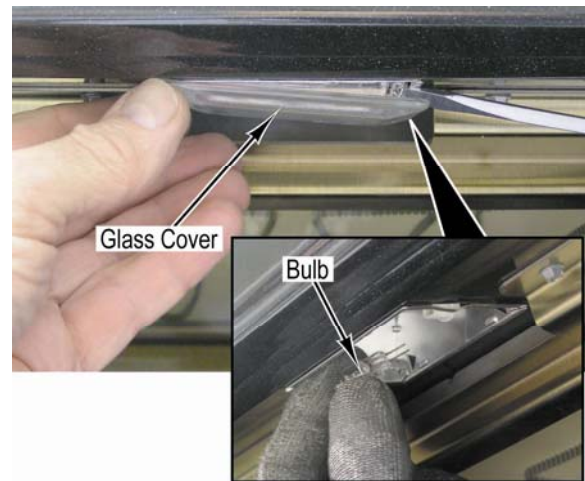

7. Replace with a 12V-20W bulb.
8. Replace the light cover by pressing it back into place.

Temperature Sensor (RTD) Removal

The Temperature Sensor (RTD) is located in the back of the oven cavity. It is used to sense oven temperature.

WARNING: Disconnect power to oven before servicing. Follow lockout/tagout procedures.

Condition Requirements:

Door Assembly Removed

Oven Racks Removed

1. Remove two screws that attach the sensor to the back of the oven liner.

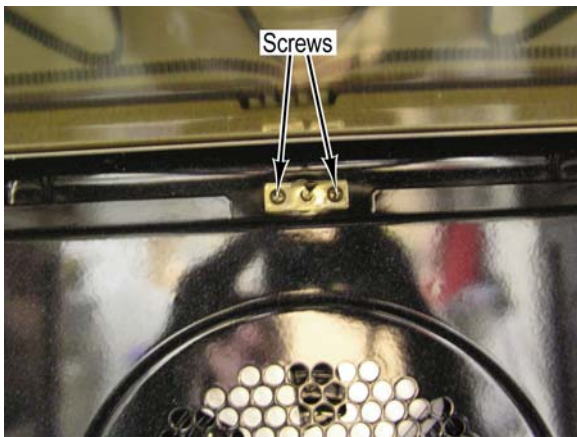

2. Pull the sensor from the liner until the sensor connector protrudes into the oven cavity.

3. Apply side pressure to the sensor connector to secure the connector against the opening in the oven liner.
4. While maintaining side pressure on the connector, disconnect the old sensor and connect the new sensor.



NOTE

When reinstalling the oven sensor, it may be helpful to insert a small screwdriver or awl into the connector and push the wiring and connector into place.

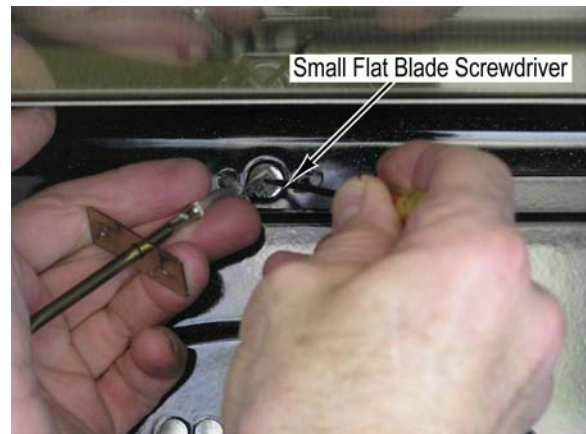

5. Install two screws that attach the sensor to the back of the oven liner.

Broil Element Removal

Glass Enclosed

WARNING: Disconnect power to oven before servicing. Follow lockout/tagout procedures.

Condition Requirements:
Door Assembly Removed

1. Remove 13 screws that hold the broil assembly to the oven cavity.

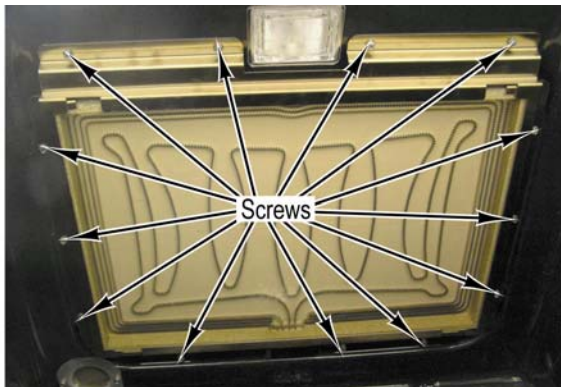

2. Carefully lower the broil assembly.

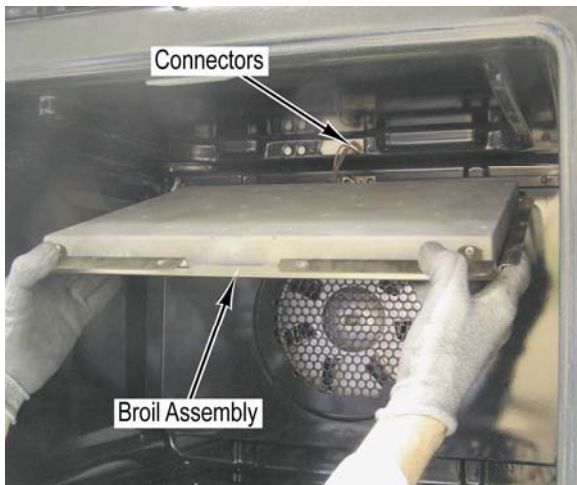

3. Pull four connectors through the oven cavity wall.
4. Mark and disconnect the four wires from the broil assembly.
5. Separate the housing from the broil assembly.
6. Reverse procedure for installation.

Tubular Style

WARNING: Disconnect power to oven before servicing. Follow lockout/tagout procedures.

Condition Requirements:
Door Assembly Removed

1. Remove six screws that hold the broil assembly to the top of the oven cavity.
2. Remove two screws that hold the broil assembly to the back of the oven cavity.

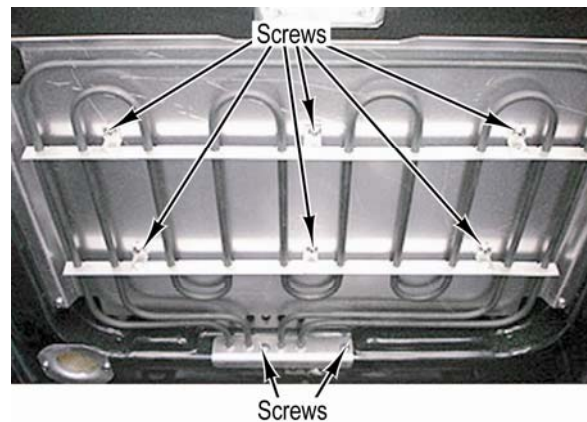

3. Carefully lower the broil assembly.

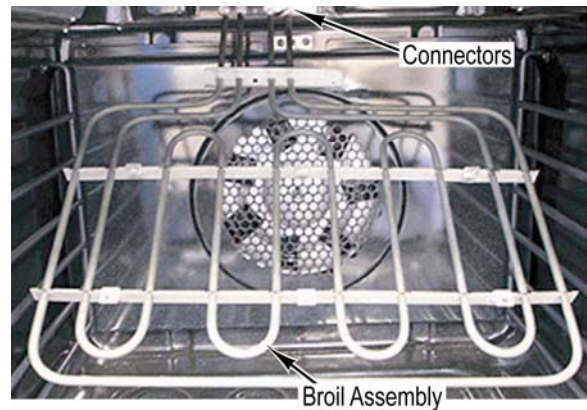

4. Pull four connectors through the oven cavity wall.
5. Mark and disconnect the four wires from the broil assembly.
6. Reverse procedure for installation.

Bake Element Removal

WARNING: Disconnect power to oven before servicing. Follow lockout/tagout procedures.

Condition Requirements:

Door Assembly Removed

1. Remove the two screws that hold the bake element access panel to the oven frame.

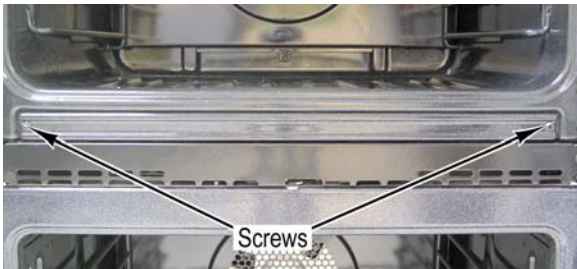

2. Remove the insulation from the recess.



3. Remove the two screws that attach the bake element to the element shelf.



4. Slide the bake element partially out, mark and disconnect the four wires from the bake element.

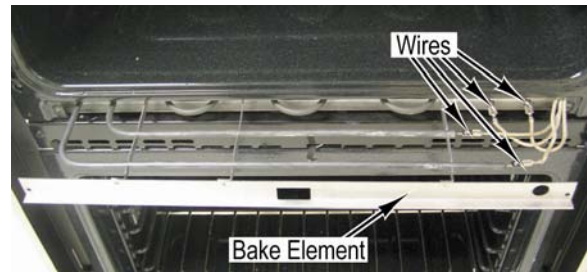

5. Remove the bake element from the oven



6. Reverse procedure for installation.

Catalyst Removal

Condition Requirements:

Convection Baffle Removed

1. Remove the two screws that hold the oven catalyst to the top, left, rear corner of the oven liner.
2. Pull down the oven catalyst.

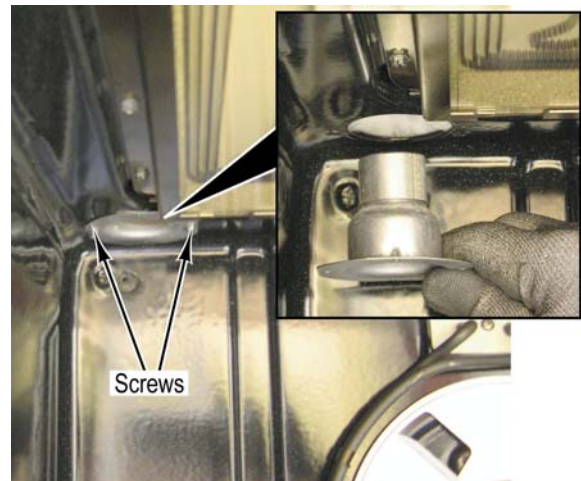

3. Reverse procedure for installation.

Convection Baffle Removal

Condition Requirements:

Door Assembly Removed

1. Remove four screws and the oven rack support from the oven cavity.

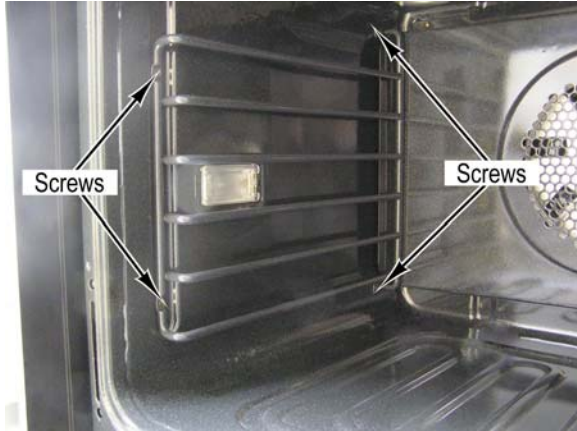

2. Remove three screws that attach the convection baffle to the oven cavity.

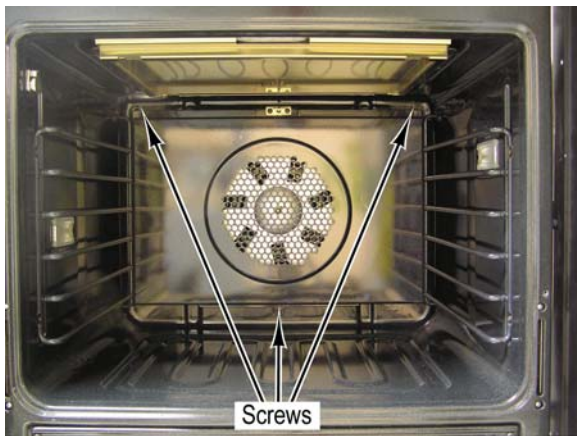

3. Reverse procedure for installation.

Convection Bake Element Removal

WARNING: Disconnect power to oven before servicing. Follow lockout/tagout procedures.

Condition Requirements:

Convection Baffle Removed

1. Remove two screws that hold the convection element to the rear of the oven cavity.

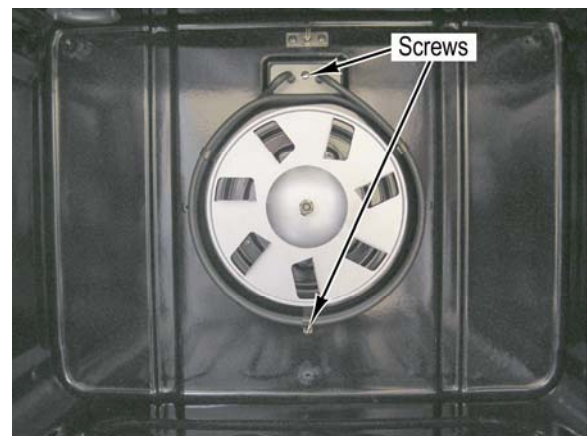

2. Disconnect two wires from the convection element.

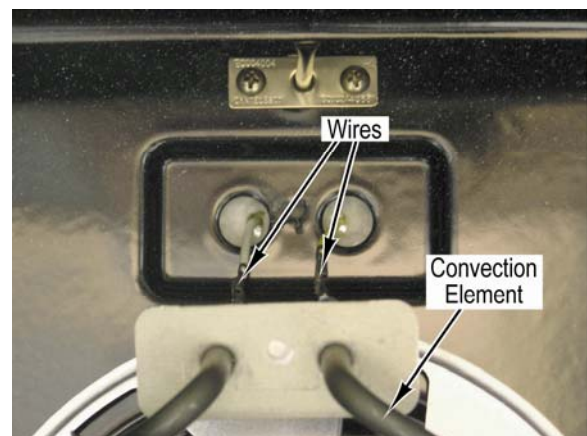

3. Reverse procedure for installation.

Convection Fan Motor Removal

WARNING: Disconnect power to oven before servicing. Follow lockout/tagout procedures.

Condition Requirements:

Convection Baffle Removed

1. Remove the six screws that hold the convection fan assembly to the rear of the oven liner.

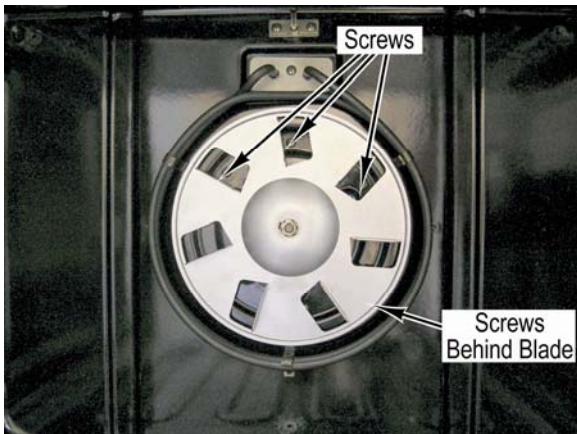

2. Disconnect the convection fan motor wire harness.

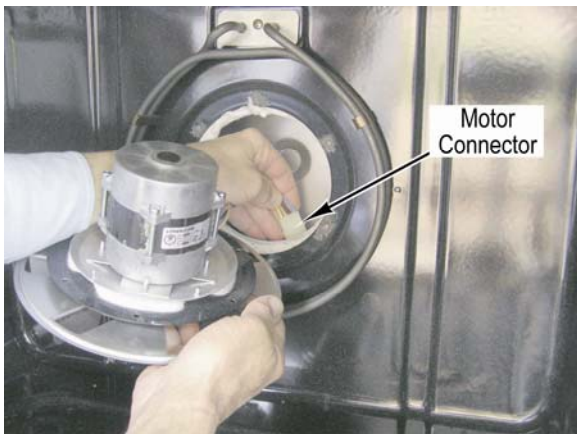

3. Reverse procedure for installation.

Convection Fan Blade Removal

Condition Requirements:

Convection Baffle Removed

1. Loosen the fan setscrew counterclockwise two to three turns.
2. Remove the 1/2 inch nut from the fan.

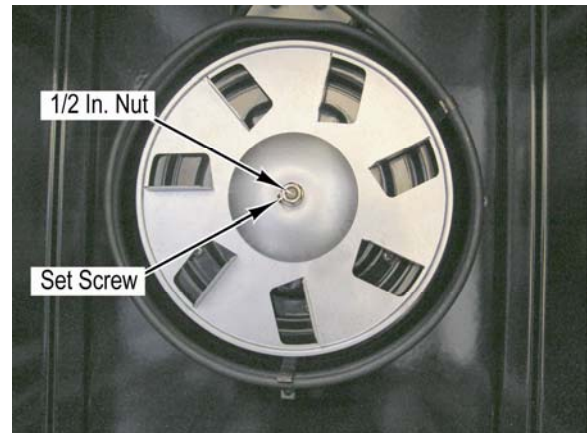

3. Lift the fan blade from the fan motor shaft.

NOTE

Upon reassembly, tighten the 1/2 inch fan nut BEFORE tightening setscrew to the flat surface on the fan motor shaft.

4. Reverse procedure for installation.

Access to Control Components

The Control Components are located on top of the oven. Access is required in order to perform many troubleshooting procedures and remove some control components. The single and double ovens are similar. The upper oven controls are on the left side and the lower oven controls are on the right. Partial or full access may be required depending on the component being tested or removed.

Partial Access

DANGER: ONLY TRAINED AND QUALIFIED TECHNICIANS SHOULD TROUBLESHOOT THIS OVEN WITH POWER CONNECTED. USE EXTREME CARE TO AVOID ELECTRIC SHOCK WHEN TESTING COMPONENTS.

WARNING: Disconnect power to oven before servicing. Follow lockout/tagout procedures.

CAUTION: Some areas of the oven interior are sharp; wear protective gloves to avoid injury.

Condition Requirements:
Oven Partially Removed

1. Remove eight screws and the top front component access panel.

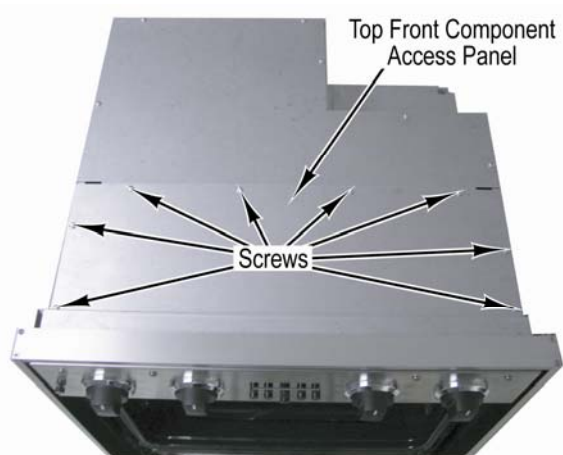

2. Reverse procedure for installation.

Full Access

DANGER: ONLY TRAINED AND QUALIFIED TECHNICIANS SHOULD TROUBLESHOOT THIS OVEN WITH POWER CONNECTED. USE EXTREME CARE TO AVOID ELECTRIC SHOCK WHEN TESTING COMPONENTS.

WARNING: Disconnect power to oven before servicing. Follow lockout/tagout procedures.

CAUTION: Some areas of the oven interior are sharp; wear protective gloves to avoid injury.

Condition Requirements:
Oven Fully Removed

1. Remove six screws and the top rear component access panel.

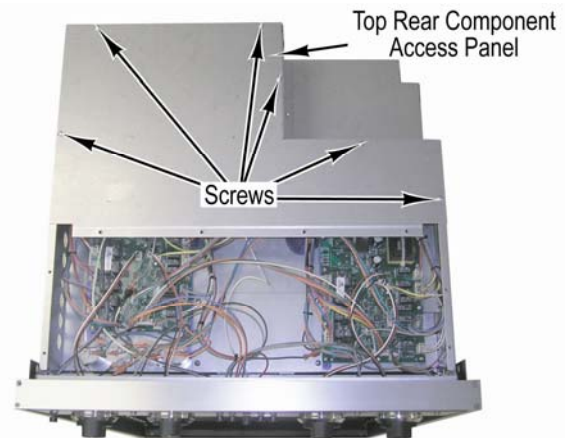

2. Reverse procedure for installation.

Oven Function Selector Removal

The Oven Function Selector is located on the control panel. It is used to select the oven function (i.e., Bake, Broil, and TruConvec, etc). It is a potentiometer and has a black cover on the rear to distinguish it from the thermostat which has a red cover.

WARNING: Disconnect power to oven before servicing. Follow lockout/tagout procedures.

CAUTION: Some areas of the oven interior are sharp; wear protective gloves to avoid injury.

Condition Requirements:

Partial Access to Control Components

1. With the knob in the off position, remove the knob from the oven function selector.
2. Remove two screws, bezel, and the oven function selector from the control panel.



3. Disconnect connector from the oven function selector.

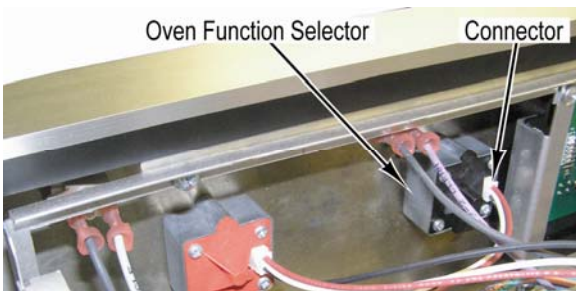

4. Reverse procedure for installation.

Oven Thermostat Removal

The Oven Thermostat is located on the control panel. It is used to set the oven temperature. It is a potentiometer and has a red cover on the rear to distinguish it from the oven function selector which has a black cover.

WARNING: Disconnect power to oven before servicing. Follow lockout/tagout procedures.

CAUTION: Some areas of the oven interior are sharp; wear protective gloves to avoid injury.

Condition Requirements:

Partial Access to Control Components

1. With the knob in the off position, remove the knob from the thermostat.
2. Remove two screws, bezel, and the thermostat from the control panel.



3. Disconnect connector from the thermostat.

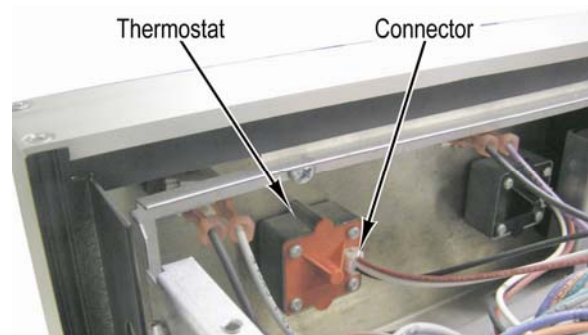

4. Reverse procedure for installation.

Oven Control Board Removal

The Oven Control Board is located above the oven cavity in the front of the component compartment. It is used to control all oven functions. Double ovens have two control boards, one for each oven. The upper oven control board is on the left and the lower oven control board is on the right.

WARNING: Disconnect power to oven before servicing. Follow lockout/tagout procedures.

CAUTION: Some areas of the oven interior are sharp; wear protective gloves to avoid injury.

Condition Requirements:

Partial Access to Control Components

1. Disconnect all connectors from the control board.
2. Remove six screws and the control board from the oven

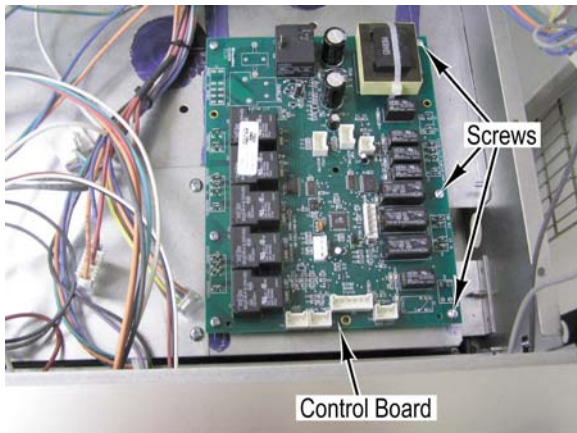

3. Reverse procedure for installation.

Oven Light Switch Removal

The Oven Light Switch is located on the control panel. It is used to turn the oven lights on or off.

WARNING: Disconnect power to oven before servicing. Follow lockout/tagout procedures.

CAUTION: Some areas of the oven interior are sharp; wear protective gloves to avoid injury.

Condition Requirements:

Partial Access to Control Components

1. Pull to remove the button from the switch.
2. Remove the knurled nut and the light switch from the control panel.
3. Disconnect the light switch wires at the connectors.

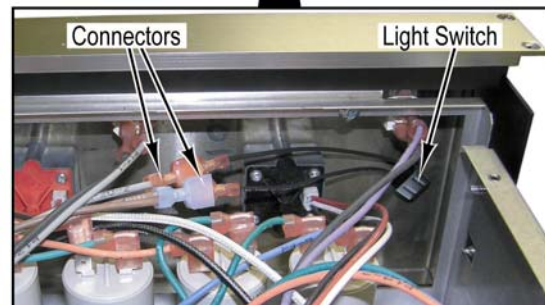
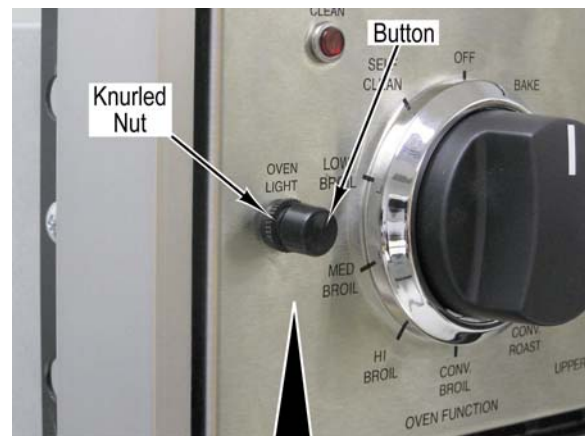

4. Reverse procedure for installation.

Oven Cycle/Clean Indicator Lights Removal

The Oven Cycle/Clean Indicator Lights are located on the control panel. The Oven Cycle Indicator Light is used to indicate when an oven element is on. The Clean Indicator Light is on when the oven is in self-clean mode.

WARNING: Disconnect power to oven before servicing. Follow lockout/tagout procedures.

CAUTION: Some areas of the oven interior are sharp; wear protective gloves to avoid injury.

Condition Requirements:

Partial Access to Control Components

1. Hold the red lens and slide off the indicator light. The indicator light will only slide in one direction.
2. Disconnect two connectors from the indicator light.

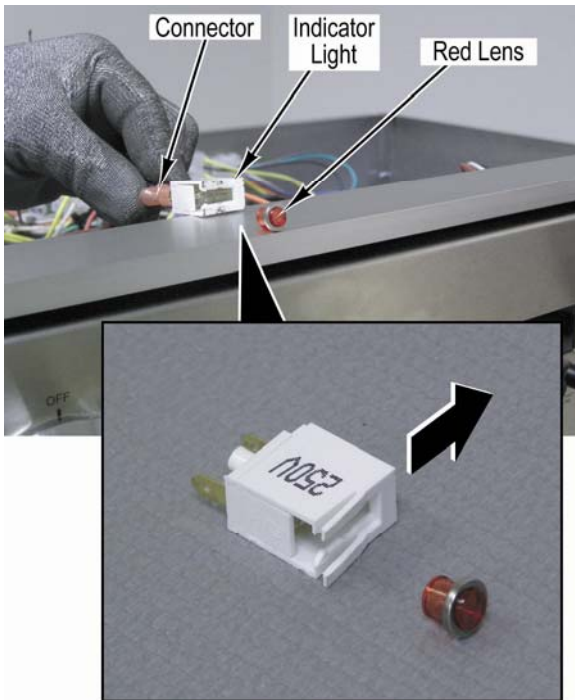

3. Reverse procedure for installation.

Oven Timer/Clock Removal

The Oven Timer/Clock is located on the control panel. It is used to control the meat probe, bake time, and automatic bake functions. The digital and analog styles are replaced using the same procedures.

Digital Timer

WARNING: Disconnect power to oven before servicing. Follow lockout/tagout procedures.

CAUTION: Some areas of the oven interior are sharp; wear protective gloves to avoid injury.

Condition Requirements:

Partial Access to Control Components

1. Pull to remove one knob and four buttons from the digital timer.

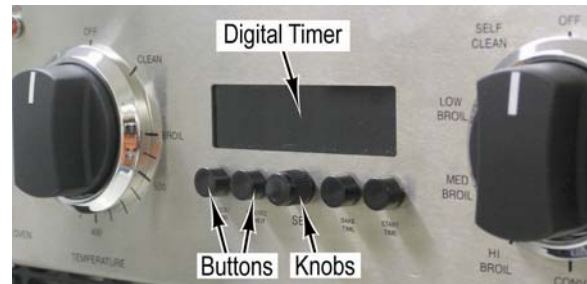

2. Remove two screws from each side of the control panel assembly.
3. Lower the control panel assembly forward leaving the panel in the three tabs along the bottom of the panel.

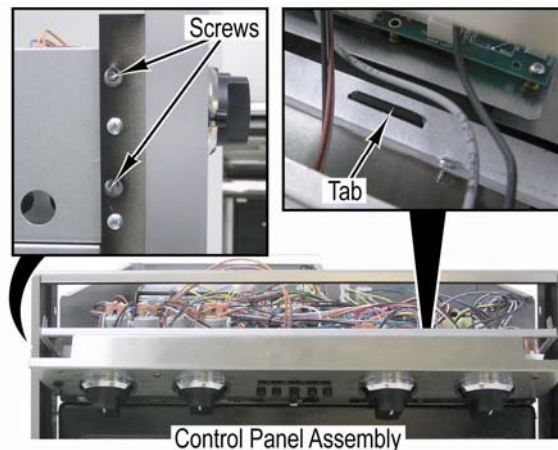

4. Disconnect connectors from the timer.
The number of connectors will vary depending on the number of ovens and features available.
5. Remove four screws and the digital timer from the control panel assembly.

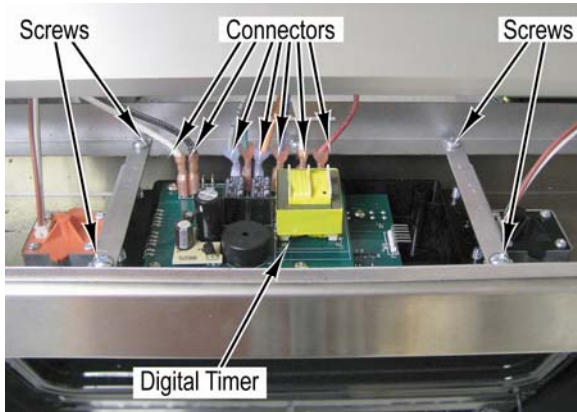

6. Remove two screws and mounting bracket from each side of the timer.

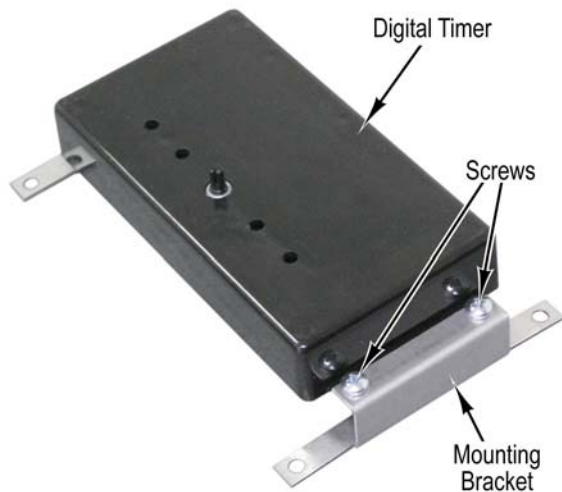

7. Reverse procedure for installation.

Analog Timer

WARNING: Disconnect power to oven before servicing. Follow lockout/tagout procedures.

CAUTION: Some areas of the oven interior are sharp; wear protective gloves to avoid injury.

Condition Requirements:

Partial Access to Control Components

1. Pull to remove one knob from the analog timer.



NOTE

Follow steps 2 through 6 of the digital timer removal. The analog timer will look slightly different; however the procedure is the same.

2. Reverse procedure for installation.

Convection Motor Capacitors Removal

The Convection Motor Capacitors are located above the oven cavity in the front of the component compartment. They are used to control the direction and speed of convection motor. Each convection motor has two capacitors.

WARNING: Disconnect power to oven before servicing. Follow lockout/tagout procedures.

CAUTION: Some areas of the oven interior are sharp; wear protective gloves to avoid injury.

Condition Requirements:

Partial Access to Control Components

1. Remove two screws from each side of the control panel assembly.
2. Lower the control panel assembly forward leaving the panel in the three tabs along the bottom of the panel.

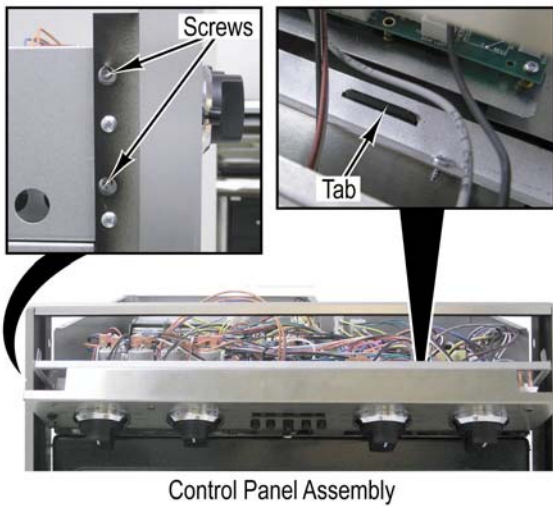

CAUTION: Use care when lifting the control panel assembly from the tabs. The weight of the control panel assembly could pull wires from connectors. It will be necessary to remove some connectors from the control panel assembly or the control board to gain access to the bottom of the capacitor. Tag and mark any connectors before removal.

3. Lift the control panel off three tabs.

WARNING: A capacitor may maintain a charge even after power has been disconnected. Use care when discharging the capacitor to avoid electric shock.

4. Discharge the capacitor and then disconnect two connectors from the capacitor.
5. Remove 13mm nut and capacitor from the oven.

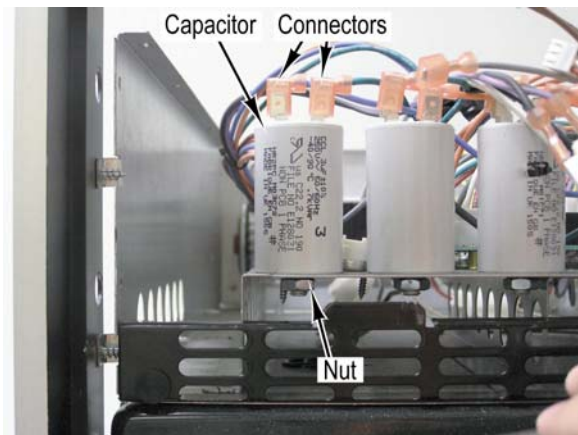

6. Reverse procedure for installation.

Thermal Cut-Out (TCO) Removal Single Oven and Upper Double Oven

The Thermal Cut-Out (TCO) for the single oven and upper double oven is located above the oven cavity in front of the capacitors. It is used as a safety device to prevent overheating of electrical components.

WARNING: Disconnect power to oven before servicing. Follow lockout/tagout procedures.

CAUTION: Some areas of the oven interior are sharp; wear protective gloves to avoid injury.

Condition Requirements:

Partial Access to Control Components

1. Remove two screws from the upper oven TCO.
2. Disconnect two connectors from the TCO.

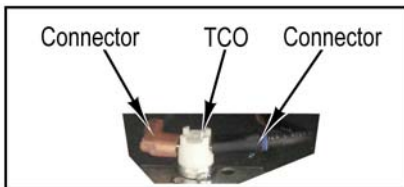

3. Reverse procedure for installation.

Lower Double Oven

The Thermal Cut-Out (TCO) for the lower double oven is located between the upper and lower oven cavities. It is used as a safety device to prevent overheating of electrical components.

WARNING: Disconnect power to oven before servicing. Follow lockout/tagout procedures.

CAUTION: Some areas of the oven interior are sharp; wear protective gloves to avoid injury.

Condition Requirements:

Door Assembly Removed

1. Remove two screws and the lower door latch access panel.
2. Remove two ¼ hex screws from the lower oven TCO.
3. Disconnect two connectors from the TCO.

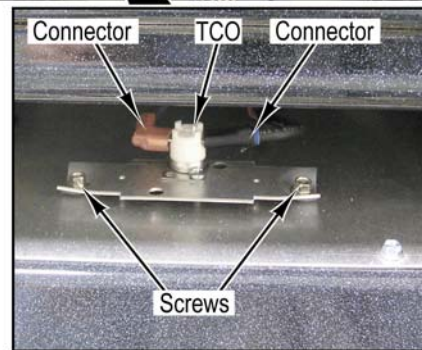
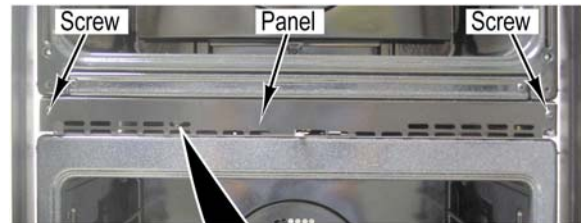

4. Reverse procedure for installation.

Door Latch Assembly Removal

Single Oven and Upper Double Oven

The Door Latch Assembly for the single oven and upper double oven is located above the oven cavity in the front of the component compartment. It is used as a safety device during the self-clean cycle.

WARNING: Disconnect power to oven before servicing. Follow lockout/tagout procedures.

CAUTION: Some areas of the oven interior are sharp; wear protective gloves to avoid injury.

Condition Requirements:

Partial Access to Control Components

1. Remove four screws and upper door latch access panel.

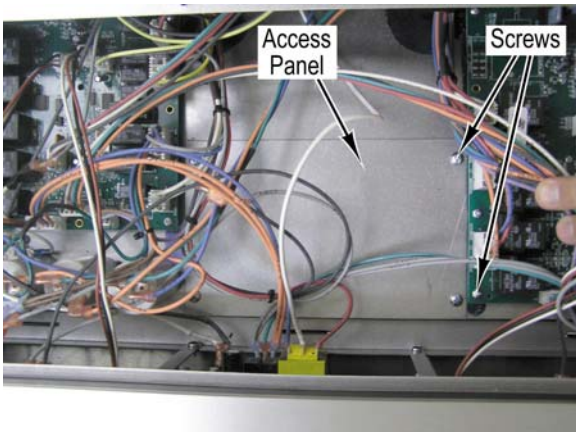

2. Remove two 1/4 hex screws from the door latch assembly.
3. Disconnect six connectors from the door latch assembly.

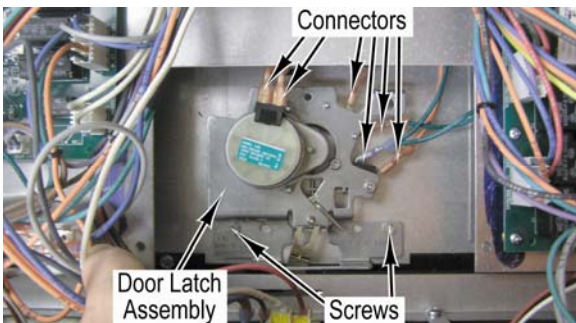

4. Reverse procedure for installation.

Lower Double Oven

The Door Latch Assembly for the lower double oven is located between the upper and lower oven cavities. It is used as a safety device during the self-clean cycle.

WARNING: Disconnect power to oven before servicing. Follow lockout/tagout procedures.

CAUTION: Some areas of the oven interior are sharp; wear protective gloves to avoid injury.

Condition Requirements:

Door Assembly Removed

1. Remove two screws and the lower door latch access panel.
2. Remove two 1/4 hex screws from the door latch assembly.

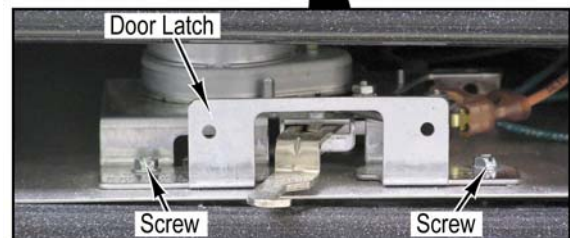
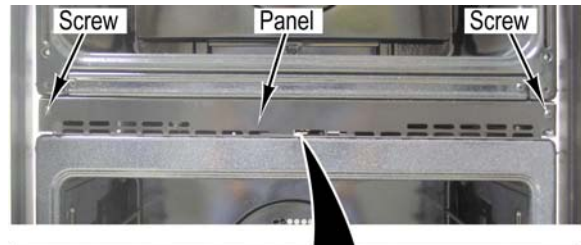

3. Disconnect six connectors from the door latch assembly.
4. Reverse procedure for installation.

Door Switch Removal

Single Oven and Upper Double Oven

The Door Switch for the single oven and upper double oven is located above the oven cavity in the front of the component compartment. It is used to sense when the upper oven door is open.

WARNING: Disconnect power to oven before servicing. Follow lockout/tagout procedures.

CAUTION: Some areas of the oven interior are sharp; wear protective gloves to avoid injury.

Condition Requirements:

Partial Access to Control Components

1. Remove one screw from the door switch and slide the door switch actuator out of the guide.

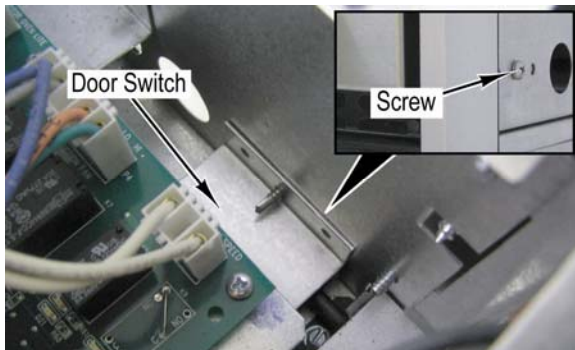

2. Pull the door switch through the access hole.
3. Disconnect two connectors from the door switch.

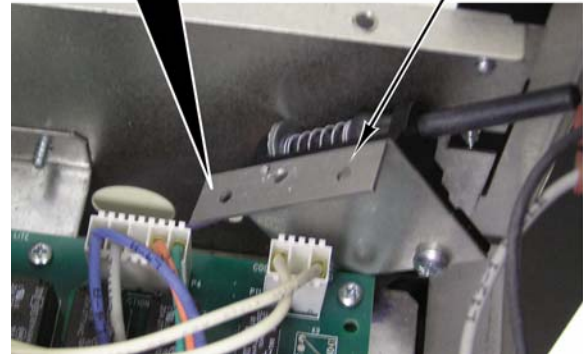
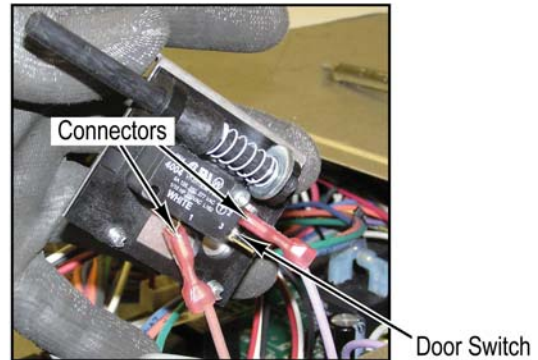

4. Reverse procedure for installation.

Lower Double Oven

The Door Switch for the lower double oven is located between the upper and lower oven cavities. It is used to sense when the lower oven door is open.

WARNING: Disconnect power to oven before servicing. Follow lockout/tagout procedures.

CAUTION: Some areas of the oven interior are sharp; wear protective gloves to avoid injury.

Condition Requirements:

Oven Partially Removed

1. Remove two screws and the lower door latch access panel.
2. Remove one screw from the door switch and slide the door switch actuator out of the guide.
3. Disconnect two connectors from the door switch.

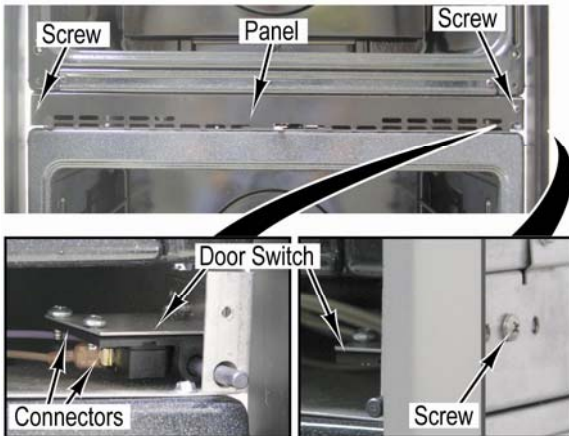

4. Reverse procedure for installation.

Oven Lights Transformer

The Oven Lights Transformer is located above the oven cavity in the rear of the component compartment. It is used to reduce the 240 volt supply power to 12 volts for the oven lights.

WARNING: Disconnect power to oven before servicing. Follow lockout/tagout procedures.

CAUTION: Some areas of the oven interior are sharp; wear protective gloves to avoid injury.

Condition Requirements:

Full Access to Control Components

1. Disconnect two connectors from the blue wires of the transformer.
2. Disconnect two connectors from the black wires of the transformer.
3. Remove two screws and the transformer from the oven.

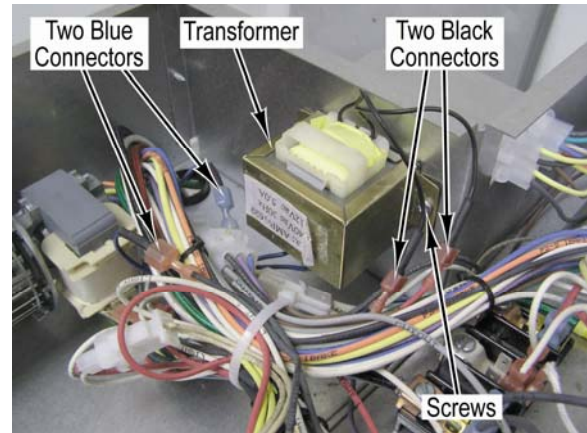

4. Reverse procedure for installation.

Blower Motor

Single Oven and Upper Double Oven

The Blower Motor for the single oven and upper double oven is located above the oven cavity in the rear of the component compartment. It is used to reduce air temperature in the component compartment.

WARNING: Disconnect power to oven before servicing. Follow lockout/tagout procedures.

CAUTION: Some areas of the oven interior are sharp; wear protective gloves to avoid injury.

Condition Requirements:

Full Access to Control Components

1. Remove three screws from the back of the oven that hold the blower motor.

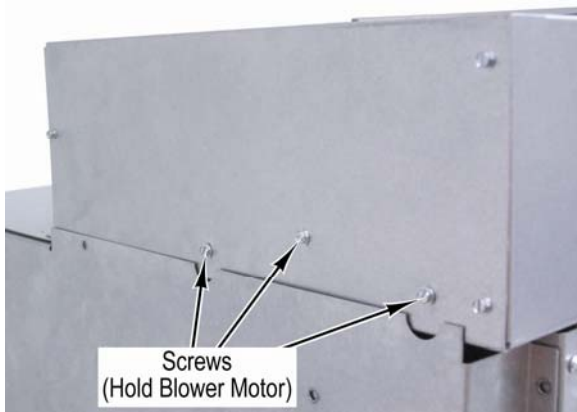

2. Remove one screw and the blower guard from the oven.
3. Disconnect two connectors from the blower motor.

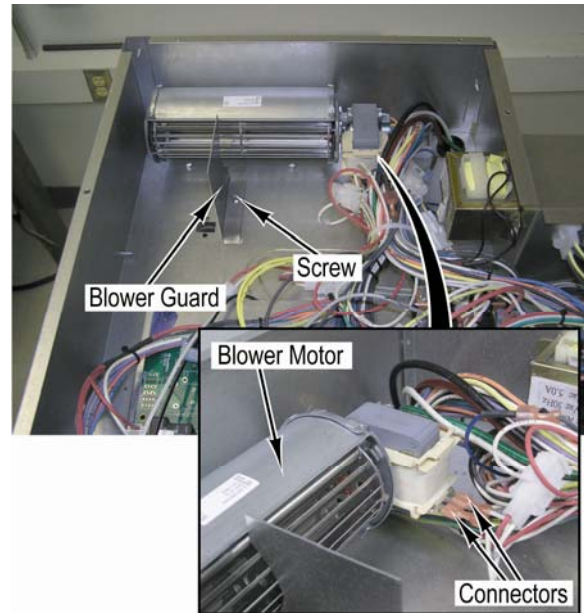

4. Reverse procedure for installation.

Lower Double Oven

The Blower Motor for the lower double oven is located on the back of the oven cavity. It is used to reduce air temperature between the oven cavities.

WARNING: Disconnect power to oven before servicing. Follow lockout/tagout procedures.

CAUTION: Some areas of the oven interior are sharp; wear protective gloves to avoid injury.

Condition Requirements:

Full Access to Control Components

1. Remove 29 screws from the back of the oven that hold on the back cover.

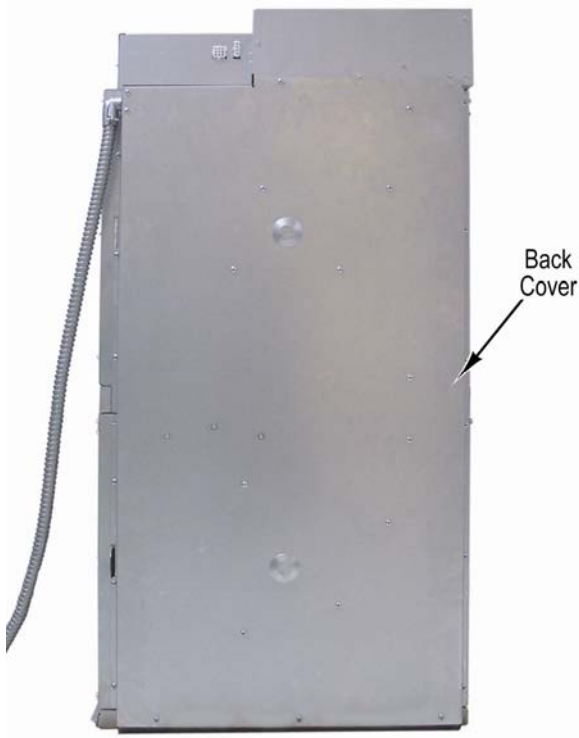

2. Remove four screws from the blower motor mounting bracket.
3. Disconnect two connectors from the blower motor.
4. Remove three screws that attach the blower motor to the mounting bracket.

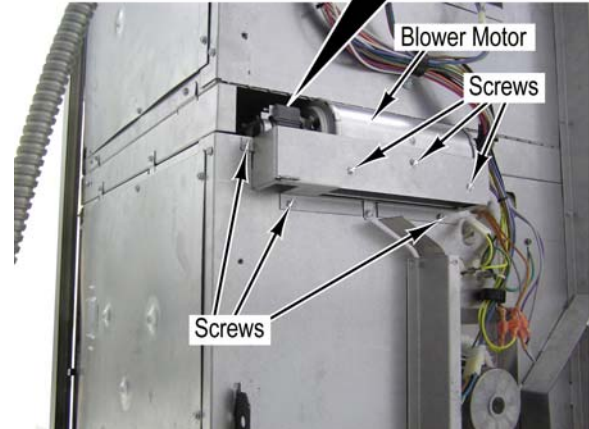
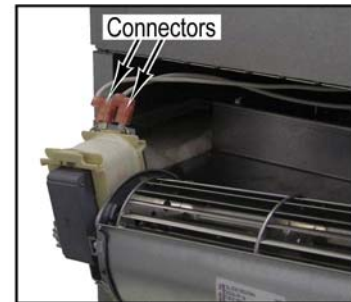

5. Reverse procedure for installation.

Door Hinge Receiver Removal

CAUTION: Some areas of the oven interior are sharp; wear protective gloves to avoid injury.

Condition Requirements:

Oven Fully Removed

1. Remove seven screws that hold the side panel to the oven.
2. Carefully pull back the side insulation from the front edge of the oven to reveal the hinge receiver.

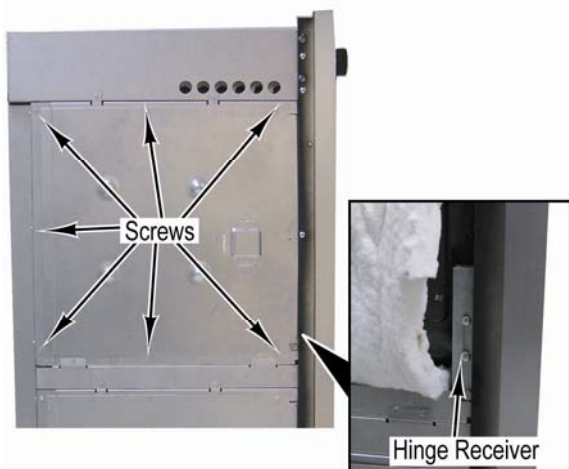

3. Remove two screws that attach the hinge receiver to the oven frame.

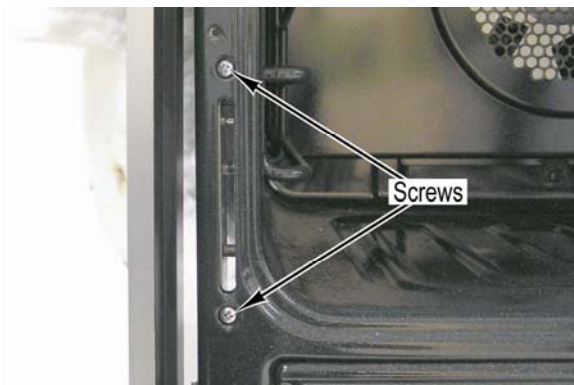

NOTE

It is important to return insulation back to original position. Replace any insulation that is missing or destroyed.

4. Reverse procedure for installation.

Meat Probe Socket Removal

CAUTION: Some areas of the oven interior are sharp; wear protective gloves to avoid injury.

Condition Requirements:

Oven Fully Removed

1. Remove seven screws that hold the side panel to the oven.
2. Carefully pull back the side insulation from the front top edge of the oven to reveal the meat probe socket.
3. Disconnect two connectors from the meat probe socket.

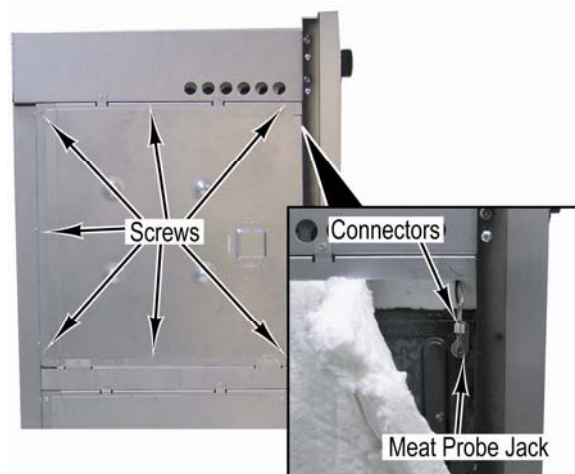

4. Lift the meat probe jack cover and remove the 5/8 inch nut that attaches the jack to the oven liner.



NOTE

It is important to return insulation back to original position. Replace any insulation that is missing or destroyed.

5. Reverse procedure for installation.



Troubleshooting

Selector and Thermostat Characteristics

The tables show the operating characteristics of the selector and thermostat positions. The selector and thermostat are potentiometers (variable resistors) whose resistance varies per user selections. The selected resistance informs the board of the user's selections.

Selector Position	Resistance – Voltage (red to black)		Resistance – Voltage (red to white)		Resistance – Voltage (black to white)	
	Resistance	Voltage	Resistance	Voltage	Resistance	Voltage
Off	10.26K Ω	5 VDC	0	5.00 VDC	0	0
Bake			5.06K Ω	0.25 VDC	9.86 K Ω	4.70 VDC
Conv. Bake			1.69K Ω	0.82 VDC	8.63 K Ω	4.09 VDC
Tru Convec.			2.89K Ω	1.40 VDC	7.47 K Ω	3.49 VDC
Conv. Roast			4.07K Ω	2.00 VDC	6.34 K Ω	2.95 VDC
Conv. Broil			5.26K Ω	2.58 VDC	5.07 K Ω	2.34 VDC
Hi Broil			6.56K Ω	3.16 VDC	3.85 K Ω	1.75 VDC
Med Broil			7.62K Ω	3.67 VDC	2.71 K Ω	1.25 VDC
Low Broil			8.77K Ω	4.21 VDC	1.53 K Ω	0.72 VDC
Self-Clean			9.91K Ω	4.75 VDC	0.41 K Ω	0.19 VDC

Resistance checks are made on the selector wire harness with the selector wire harness disconnected from the board at location P21. The harness is connected to P21 for voltage checks.

Thermostat Position	Resistance – Voltage (red to black)		Resistance – Voltage (red to white)		Resistance – Voltage (black to white)	
	Resistance	Voltage	Resistance	Voltage	Resistance	Voltage
Off	9.41K Ω	4.94 VDC	0	4.94 VDC	0	0
200°F			8.25K Ω	4.30 VDC	1.25 K Ω	0.66 VDC
300°F			6.32K Ω	3.39 VDC	3.13 K Ω	1.57 VDC
400°F			4.54K Ω	2.41 VDC	5.03 K Ω	2.48 VDC
500°F			2.88K Ω	1.51 VDC	6.61 K Ω	3.43 VDC
Broil			1.90K Ω	1.05 VDC	7.56 K Ω	3.90 VDC
Clean			0.60K Ω	0.32 VDC	8.86 K Ω	4.63 VDC

Resistance checks are made on the thermostat wire harness with the thermostat wire harness disconnected from the board at location P15. The harness is connected to P15 for voltage checks.

Component Testing

Component	Operating Voltage (approximate)	Resistance (approximate)	Test Location
Convection Element	240 VAC	18.2 Ohms	K17 yellow – P2 white
Outer Broil Element	240 VAC	30.2 Ohms	K17 yellow – P6 grey
Inner Broil Element	240 VAC	34.0 Ohms	K17 yellow – P6 purple
Outer Bake Element	240 VAC	37.2 Ohms	K17 yellow – P5 blue
Inner Bake Element	240 VAC	37.8 Ohms	K17 yellow – P5 orange
RTD (Resistive Thermal Device)	5 VDC	1100 Ohms @ 75°F (See chart for more options)	P15 pin 1 – pin 2
Convection Motor	240 VAC	100 Ohms	L2- P4 blue, L2 – P4 grey
Blower Motor(s)	120 VAC	18.2 Ohms single oven 9.3 Ohms double ovens	N– P11 white
Door Latch Motor	240 VAC	12.86K Ohms	L2 – P12 white
Door Latch Switch – door unlocked	5 VDC	Open	P19 green – orange
Door Latch Switch – door unlocked	0 VDC	Closed	P19 green – blue
Door Latch Switch – door locked	0 VDC	Closed	P19 green – orange
Door Latch Switch – door locked	5 VDC	Open	P19 green – blue
Thermal Cut-Out – open contacts	240 VAC	Open	L2 – P1 black
Thermal Cut-Out – closed contacts	0 VDC	0 Ohms	L2 – P1 black
Cycle Light	240 VAC	Open (neon light)	L2 – P12 grey
Clean Light	240 VAC	Open (neon light)	L2 – P12 purple
Oven Light Switch – off (door closed)	16.3 VDC	Open (P20 brown – grey)	P20 grey – purple
Oven Light Switch – on (door closed)	0 VDC	0 Ohms (P20 brown – grey)	P20 grey – purple
Oven Door Switch – (door closed)	0 VDC	0 Ohms (P20 brown – purple)	P20 brown – purple
Oven Door Switch – (door opened)	15.5 VDC	0 Ohms (P20 brown – purple)	P20 brown – purple



Component	Operating Voltage (approximate)	Resistance (approximate)	Test Location
Oven Light Transformer – primary	240 VAC	28 Ohms	L2 – P12 yellow
Oven Light Transformer – secondary	12 VAC	0.1 Ohms	Transformer – 2 black wires
Analog Timer	240 VAC	0.57 Ohms	Timer L1 – L2 (N)
Digital Timer	240 VAC	1.2 Ohms	Timer L1 – L2 (N)

RTD (Resistive Thermal Device)	
Temperature (°F)	Resistance (approximate)
50	1038
75	1090
100	1143
200	1350
300	1553
350	1654
400	1754
450	1852
500	1950
550	2047
600	2153
650	2238
700	2332
750	2425
800	2518
850	2609
900	2700

Troubleshooting Guide

Problem	Probable Cause	Correction
No bake, no broil, no oven lights, no power to timer L1-L2.	House breaker or fuse open. Defective oven wiring (shorted, open, or burned).	Reset breaker or replace fuse. Repair or replace defective wiring.
No bake, no broil, no oven lights, timer display on.	Open thermal cut-out. Open power board. Defective oven wiring (shorted, open, or burned).	Replace TCO. (Check operation of blower motor.) Replace power board. Repair or replace defective wiring.
No bake, timer display on, oven lights operate.	Open bake element. Open selector. Open thermostat. Open relay K10 or K11. Open power board. Defective oven wiring (shorted, open, or burned).	Replace bake element. Replace selector. Replace thermostat. Replace power board. Replace power board. Repair or replace defective wiring.
No broil, timer display on, oven lights operate.	Open broil element. Open selector. Open thermostat. Open relay K12 or K13. Open power board. Defective oven wiring (shorted, open, or burned).	Replace broil element. Replace selector. Replace thermostat. Replace power board. Replace power board. Repair or replace defective wiring.
No convection bake, timer display on, oven lights operate.	Open bake element. Open broil element. Open convection fan motor. Open selector. Open thermostat. Open relay K10, K11, K12, K13, K5, or K7. Open power board. Defective oven wiring (shorted, open, or burned).	Replace bake element. Replace broil element. Replace convection fan motor. Replace selector. Replace thermostat. Replace power board. Replace power board. Repair or replace defective wiring.
No convection roast, timer display on, oven lights operate.	Open broil element. Open convection element. Open convection fan motor. Open selector. Open thermostat Open relay K12, K13, K14, K5, K6, or K7. Open power board. Defective oven wiring (shorted, open, or burned).	Replace broil element. Replace convection element. Replace convection fan motor. Replace selector. Replace thermostat. Replace power board. Replace power board. Repair or replace defective wiring.



Problem	Probable Cause	Correction
No convection broil, timer display on, oven lights operate.	Open broil element. Open selector. Open thermostat. Open convection fan motor. Open relay K12, K13, K5 or K7. Open power board. Defective oven wiring (shorted, open, or burned).	Replace broil element. Replace selector. Replace thermostat. Replace convection fan motor. Replace power board. Replace power board. Repair or replace defective wiring.
No Tru Convec, timer display on, oven lights operate.	Open convection element. Open convection fan motor. Open selector. Open thermostat. Open relay K14, K5, or K7. Open power board. Defective oven wiring (shorted, open, or burned).	Replace convection element. Replace convection fan motor. Replace selector. Replace thermostat. Replace power board. Replace power board. Repair or replace defective wiring.
No self-clean, bake and broil operate normally, timer display on, oven lights operate, door won't lock, no clean indicator light.	Open door latch motor. Out of calibration selector. Out of calibration thermostat. Open relay K3. Open power board. Defective oven wiring (shorted, open, or burned).	Replace door latch motor. Replace selector. Replace thermostat. Replace power board. Replace power board. Repair or replace defective wiring.
No self-clean, bake and broil operate normally, timer display on, oven lights operate, door will lock, no clean indicator light.	Open door latch switch. Open power board. Defective oven wiring (shorted, open, or burned).	Replace door latch assembly. Replace power board. Repair or replace defective wiring.
Oven in self-clean mode, oven heats, no door lock indicator light (oven not reaching elevated clean temperatures).	Open door latch switch. Oven sensor out of calibration. Faulty power board. Defective oven wiring (shorted, open, or burned).	Replace door latch assembly. Replace oven sensor. Replace power board. Repair or replace defective wiring.
Oven door won't unlock (oven below elevated clean temperatures).	Open door latch motor. Oven sensor out of calibration. Faulty power board. Open relay K3. Defective oven wiring (shorted, open, or burned).	Replace door latch motor. Replace oven sensor. Replace power board. Replace power board. Repair or replace defective wiring.
Oven lights inoperable (bulbs OK).	Open light transformer windings. Open relay K4. Open power board. Defective oven wiring (shorted, open, or burned).	Replace light transformer. Replace power board. Replace power board. Repair or replace defective wiring.

Problem	Probable Cause	Correction
Blower motor inoperable.	Open blower motor. Oven sensor out of calibration. Open relay K8 or K9. Open power board. Defective oven wiring (shorted, open, or burned).	Replace blower motor. Replace oven sensor. Replace power board. Replace power board. Repair or replace defective wiring.

Oven Control Board

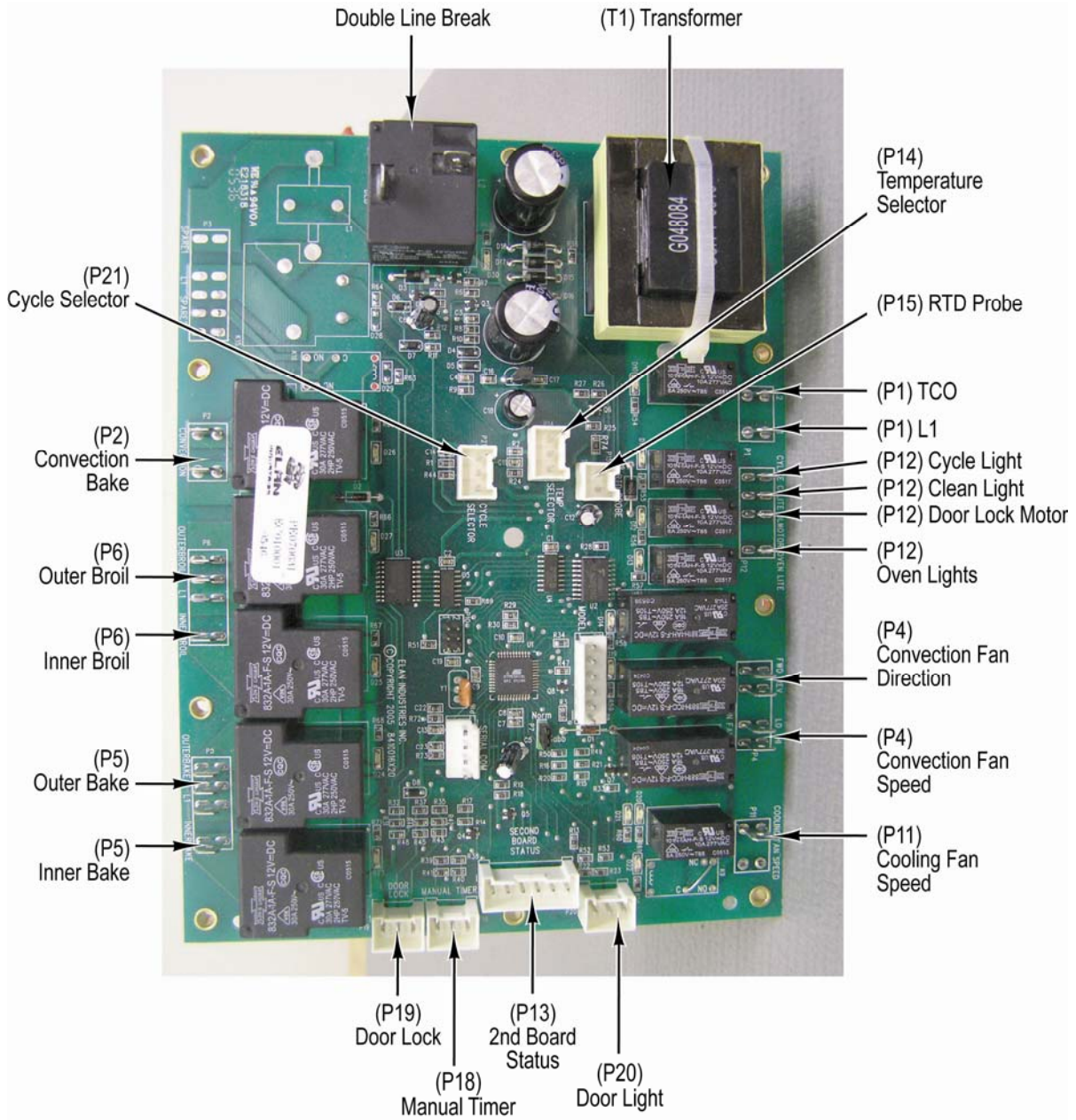

Oven Control Board Connections

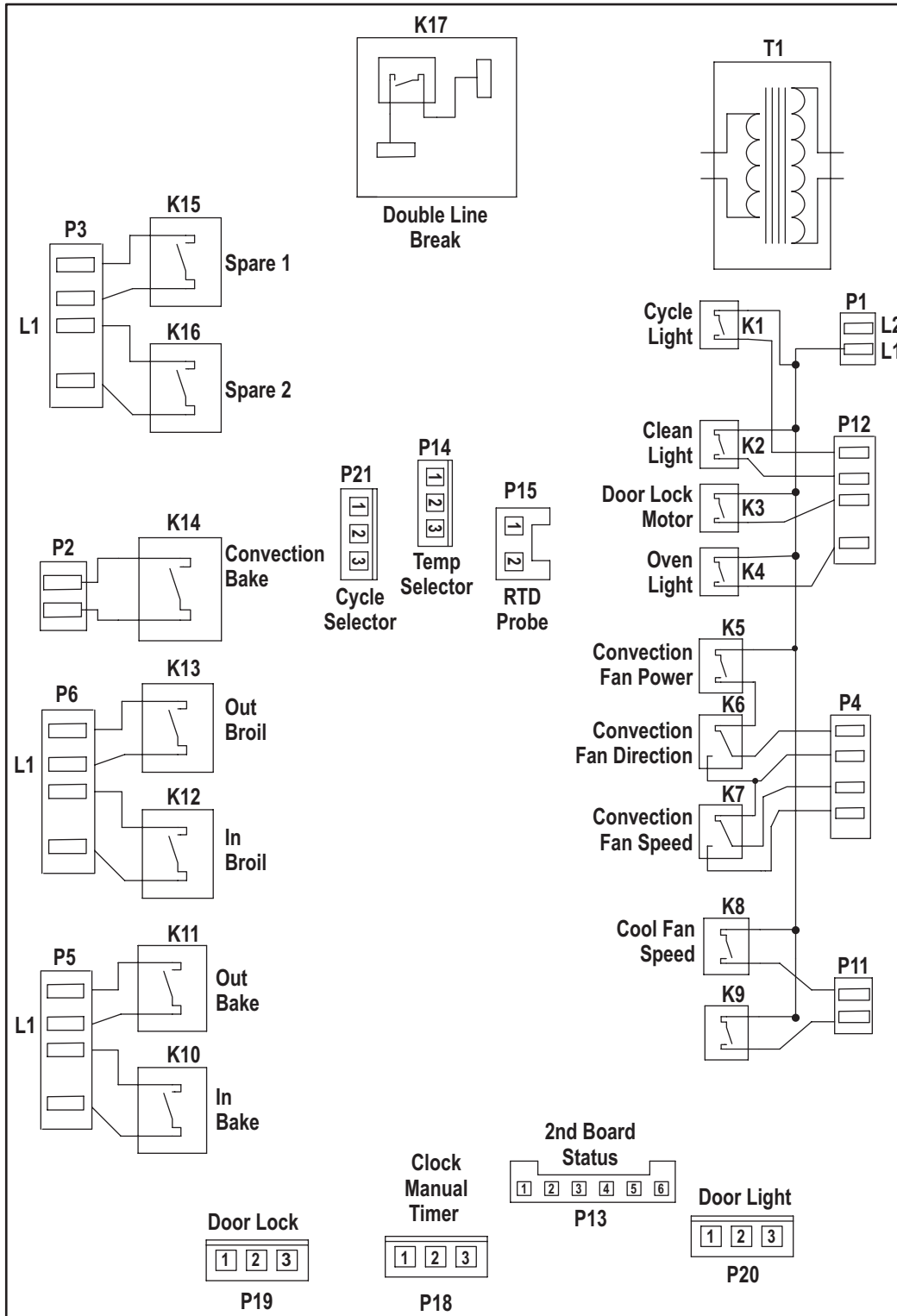

Oven Control Board Schematic

Communication between Control Boards on Double Ovens

On double ovens, the control boards use a low voltage communication to determine what functions can be performed by both ovens at the same time and in what order. For example, only one oven can be in self-clean mode at a time. If both ovens are put in self-clean mode at exactly the same time, neither will work. The first oven selected to clean will enter clean, the other will not. Once an oven is in self-clean mode, the board for that oven sends a 5VDC signal to the other board to indicate it is in use. A 5 VDC signal is also sent when an oven is in preheat. However, once an oven is in preheat, the other oven can then be set to preheat as well. The following diagrams show the communication between the two boards when self-clean or preheat is in use.

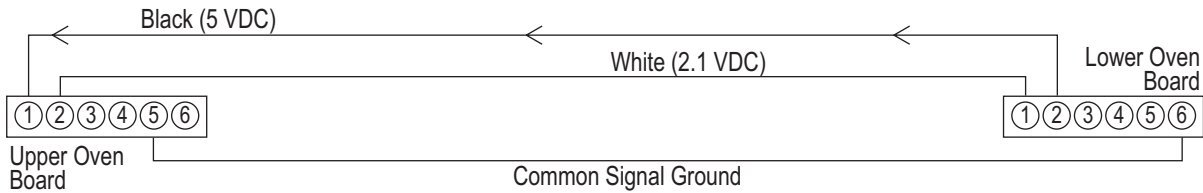

Lower Oven in Self-Clean Mode – Upper Oven Off

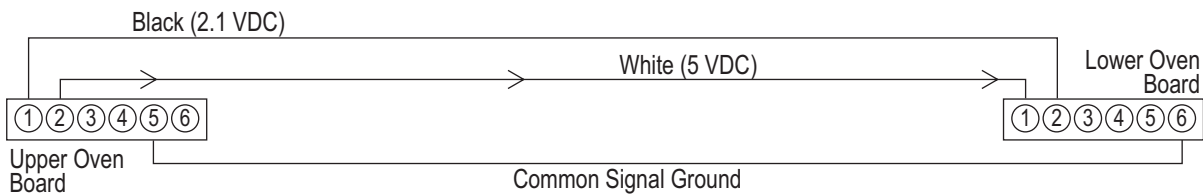

Upper Oven in Self-Clean Mode – Lower Oven Off

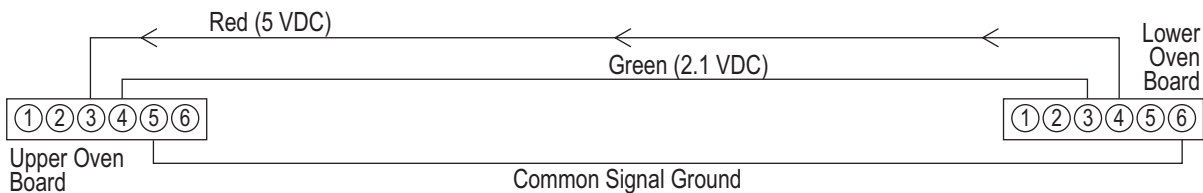

Lower Oven in Preheat – Upper Oven Off (also when lower oven selected first)

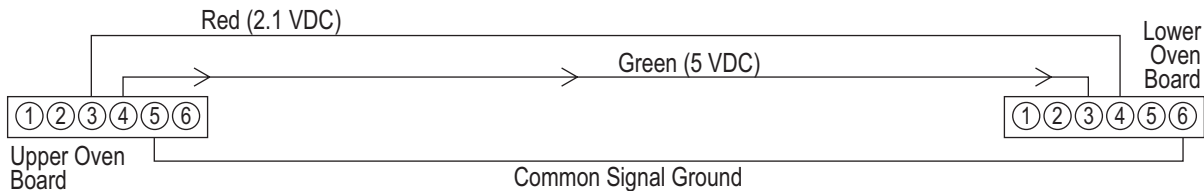

Lower Oven in Preheat – Upper Oven Off (also when lower oven selected first)

Strip Circuits and Schematics

CONVECTION ELEMENT

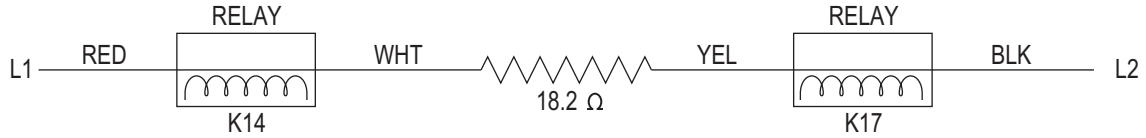

Convection Element Strip Circuit

OUTER BROIL ELEMENT

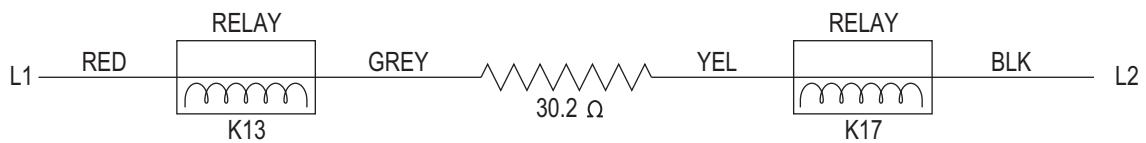

Outer Broil Element Strip Circuit

INNER BROIL ELEMENT

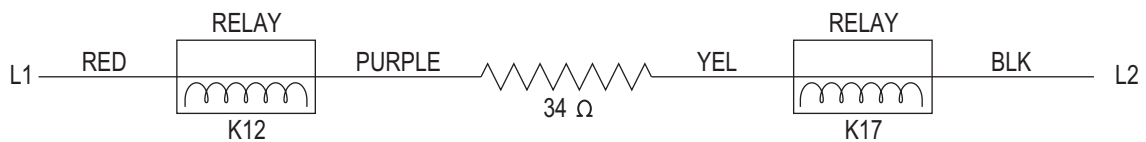

Inner Broil Element Strip Circuit

OUTER BAKE ELEMENT

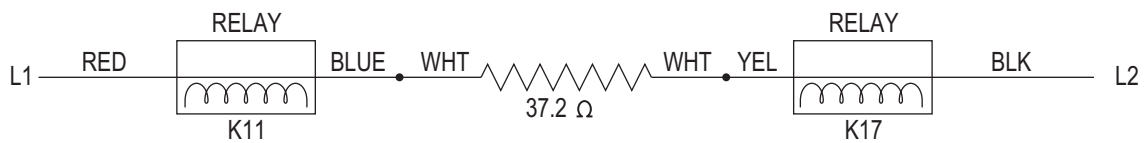

Outer Bake Element Strip Circuit

INNER BAKE ELEMENT

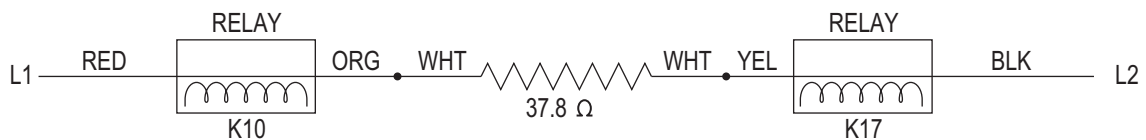

Inner Bake Element Strip Circuit

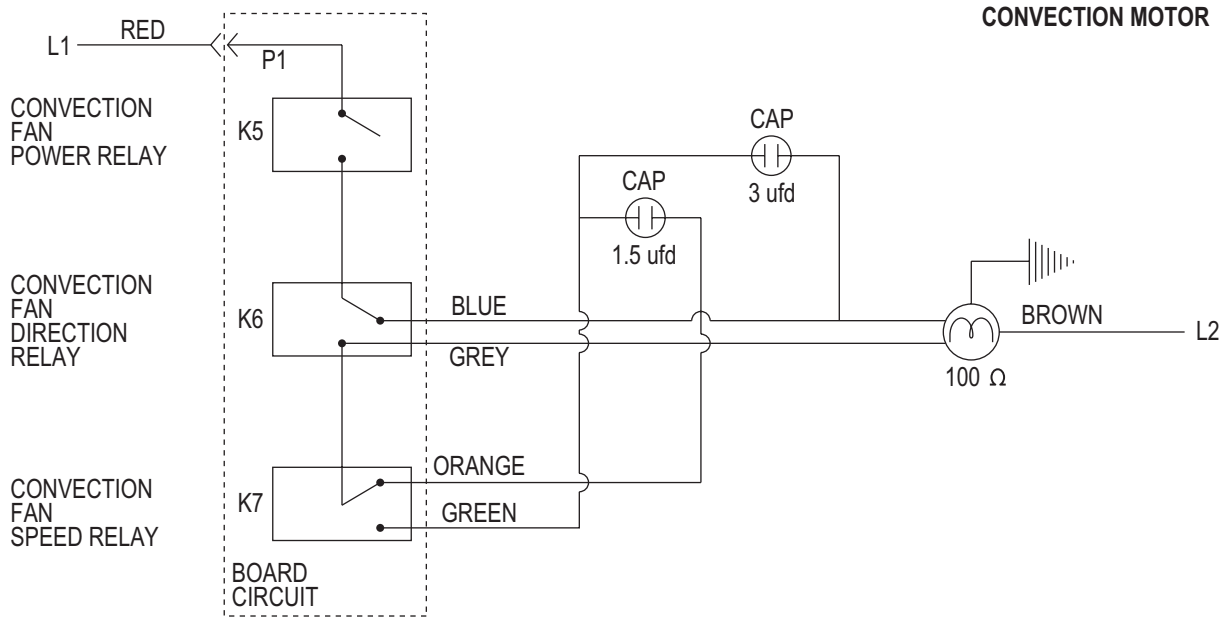

Convection Motor Strip Circuit

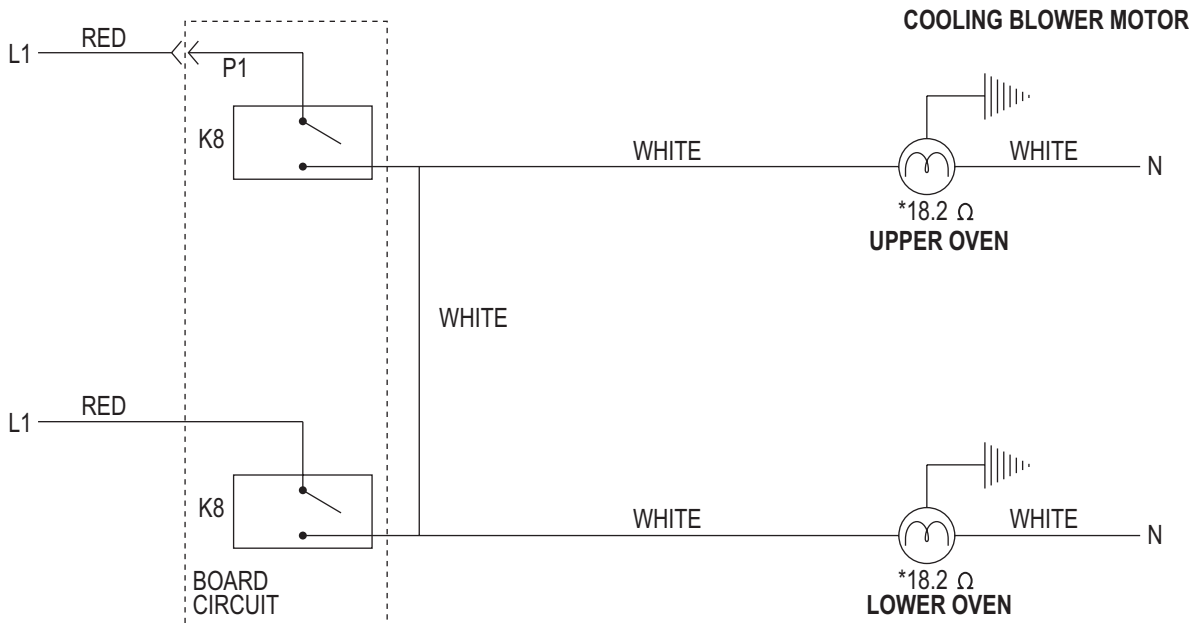

*NOTE: BLOWER MOTORS IN PARALLEL MEASURE APPROXIMATELY 9.3 Ω

Cooling Blower Motor Strip Circuit

DOOR LATCH MOTOR



Door Latch Motor Strip Circuit

LIGHT TRANSFORMER

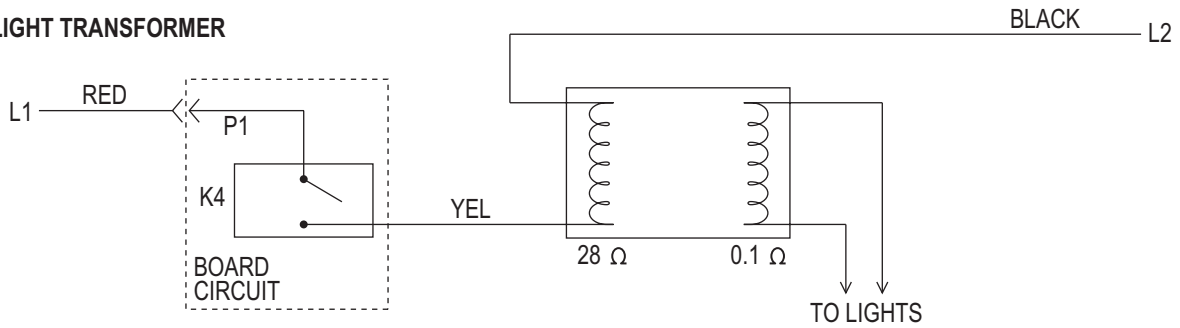

Light Transformer Strip Circuit

TIMER (DISPLAY)

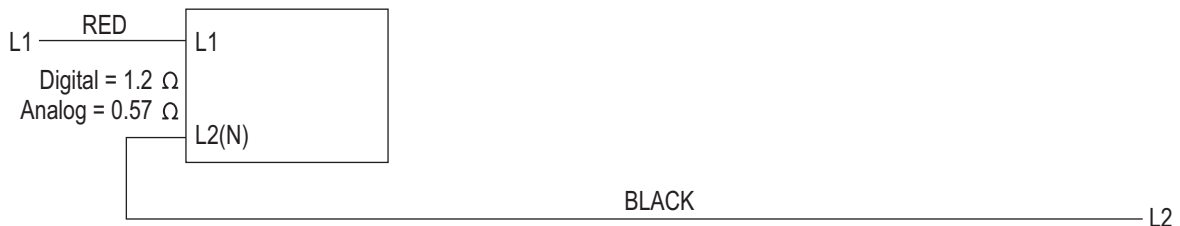

Timer Display Strip Circuit

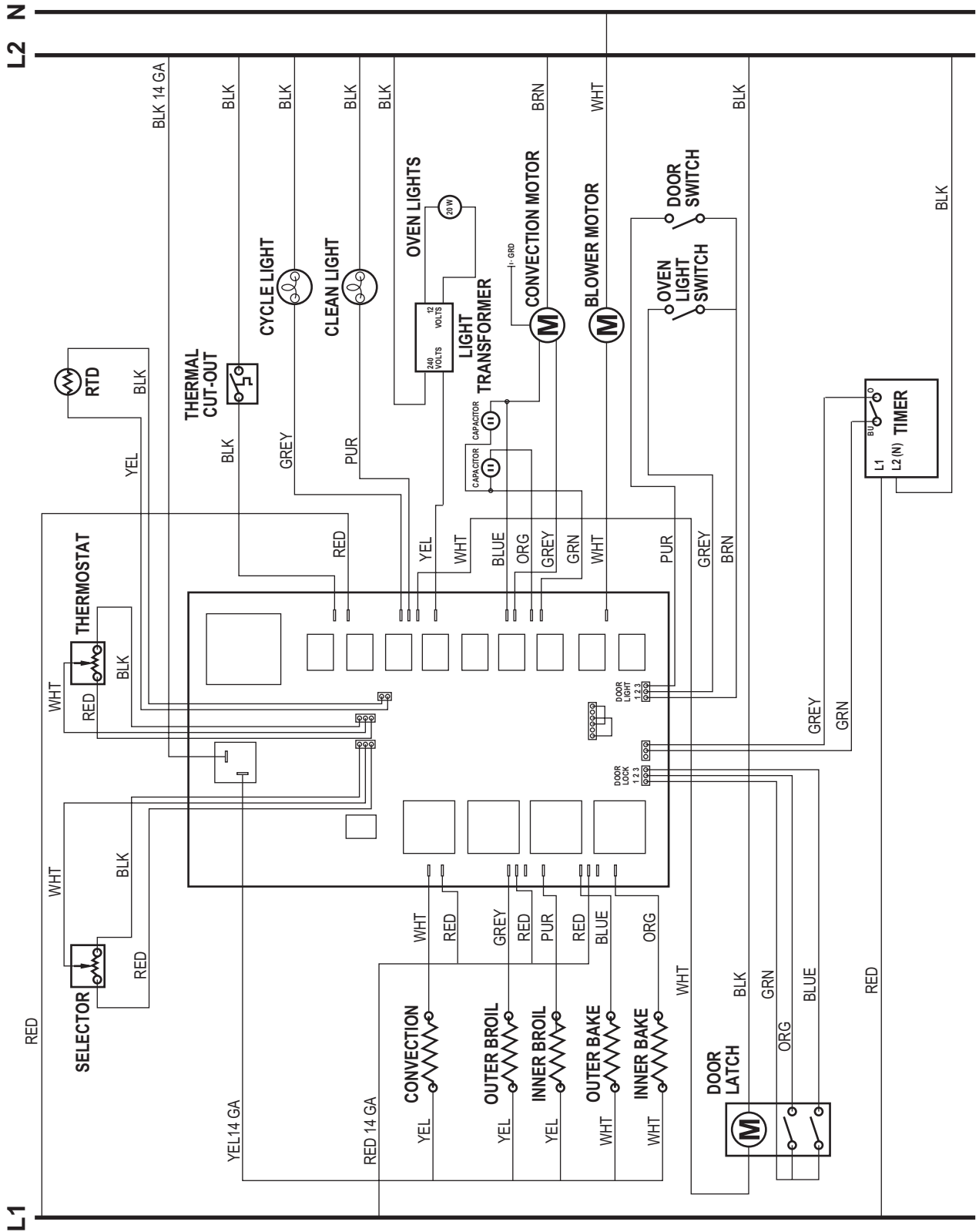

Professional Select Single Oven

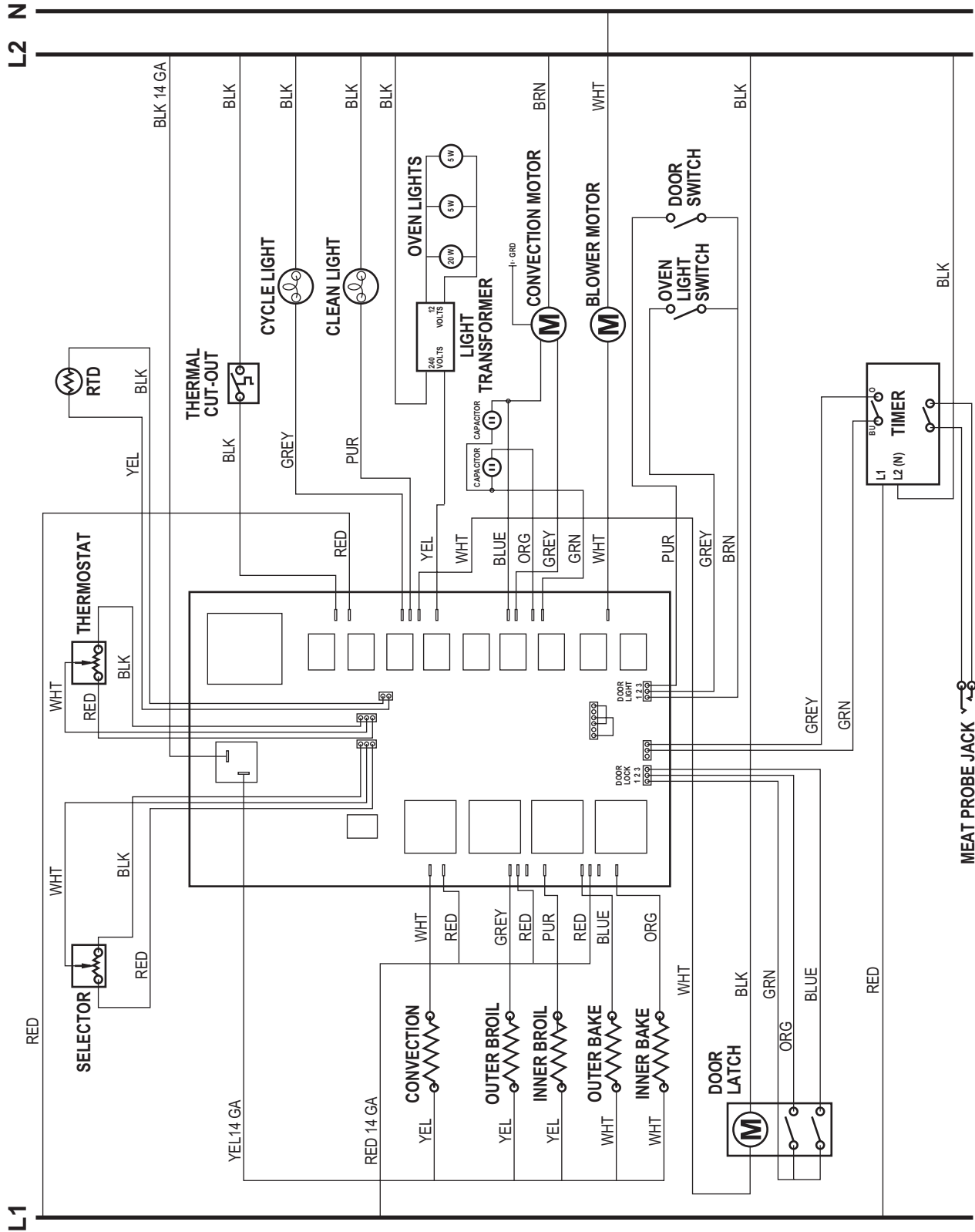

Professional Premiere Single Oven

L2 N

L1

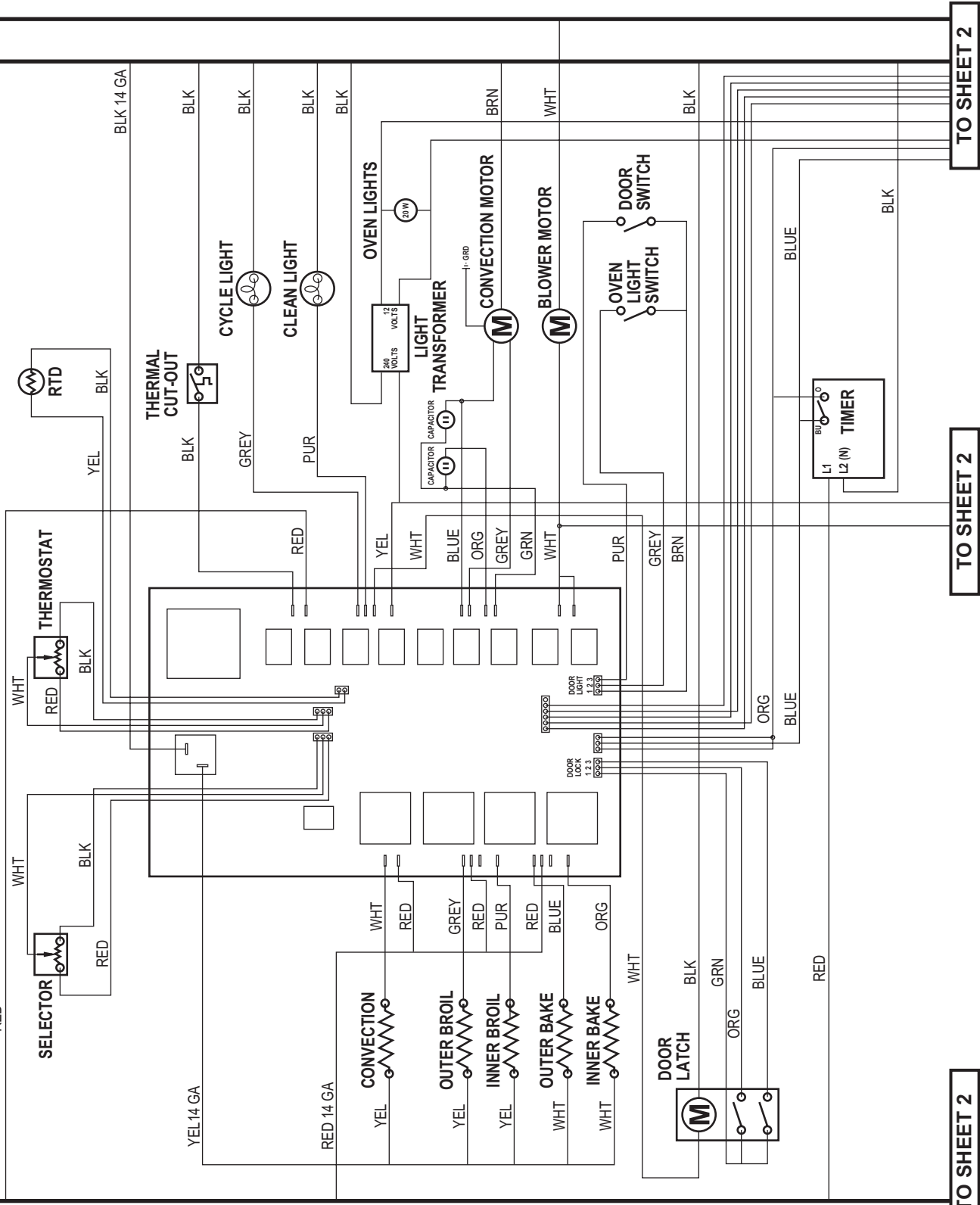

Professional Select Double Oven (Upper)

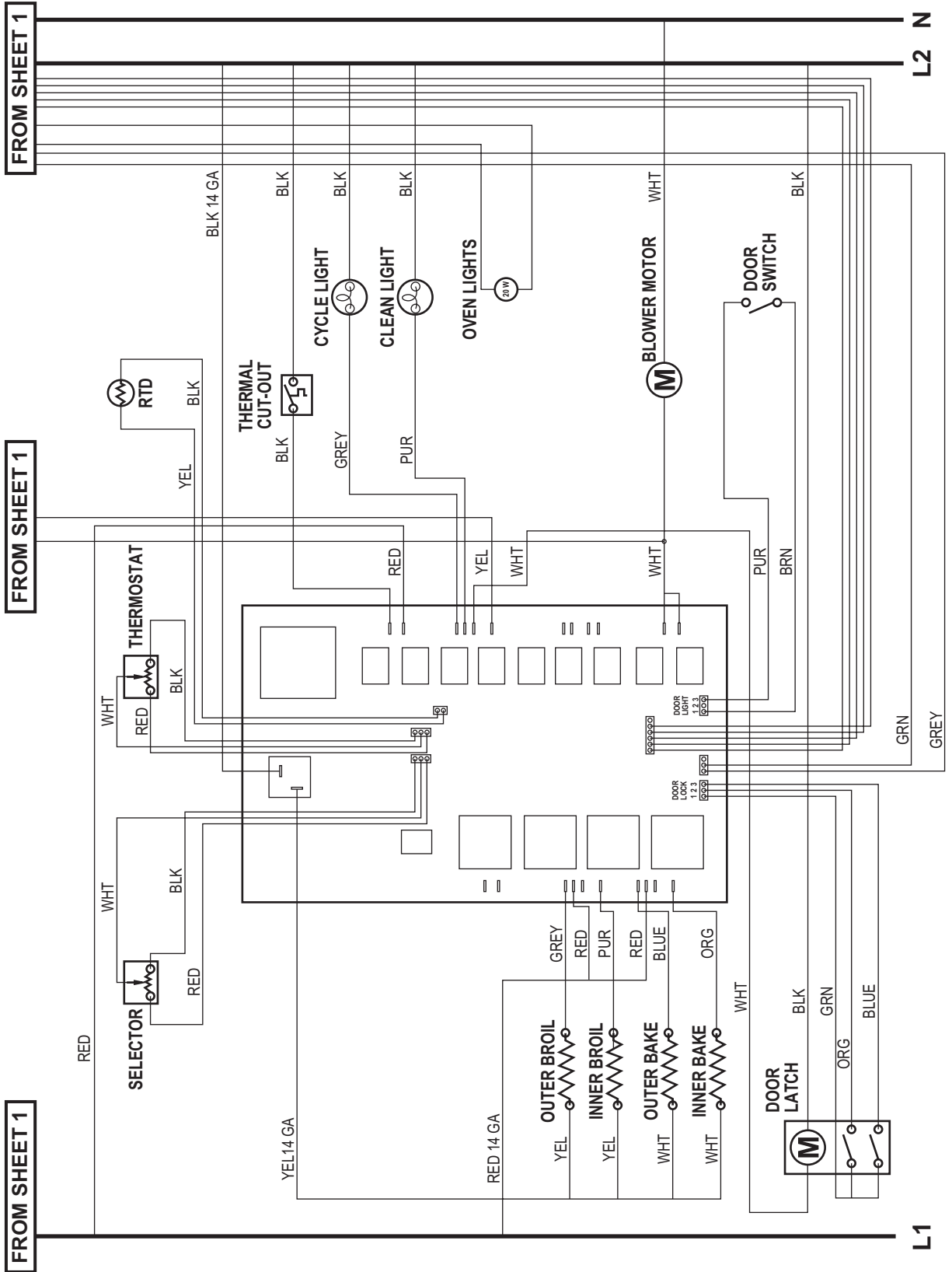

Professional Select Double Oven (Lower)

L2 N

L1

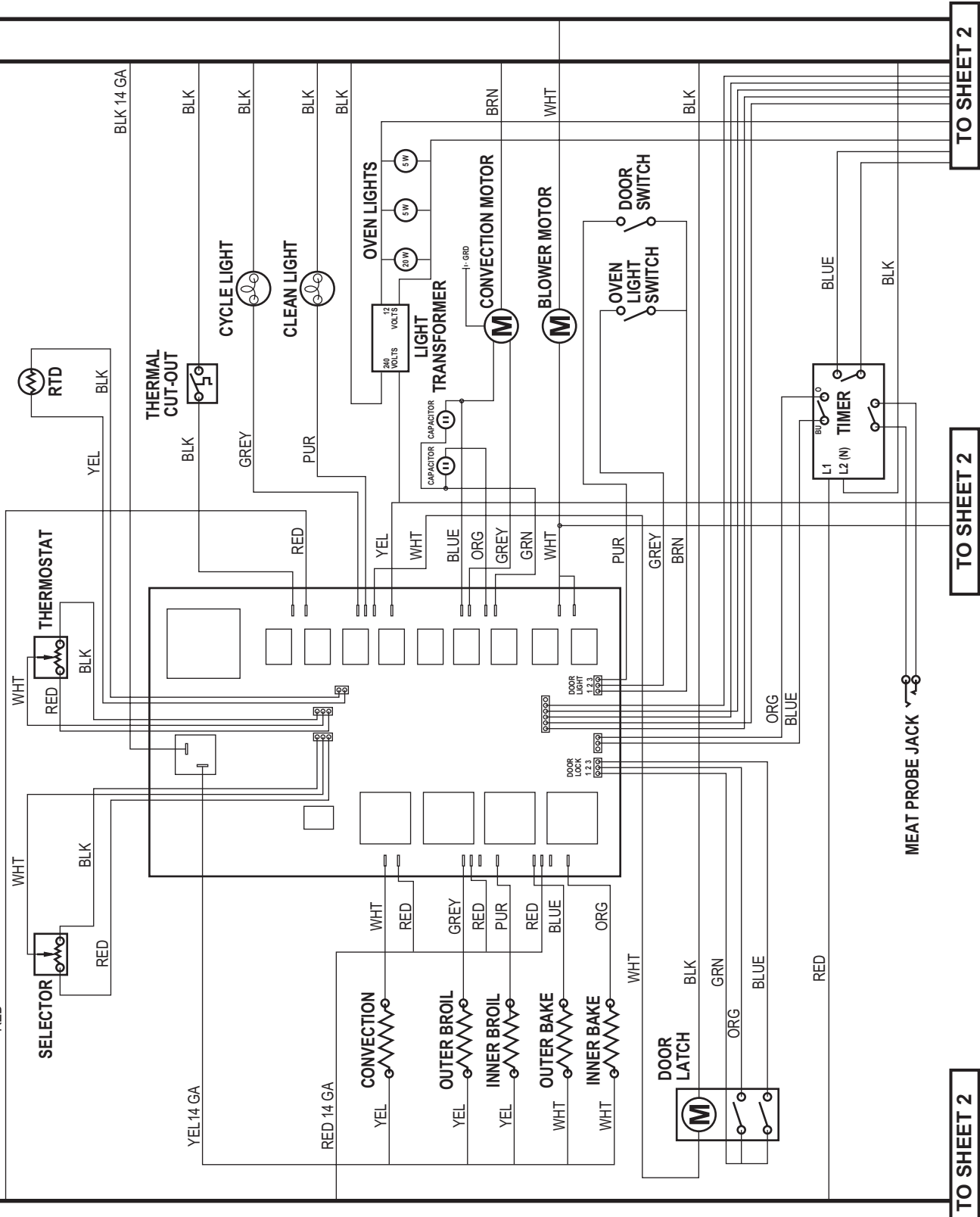

Professional Premiere Double Oven (Upper)

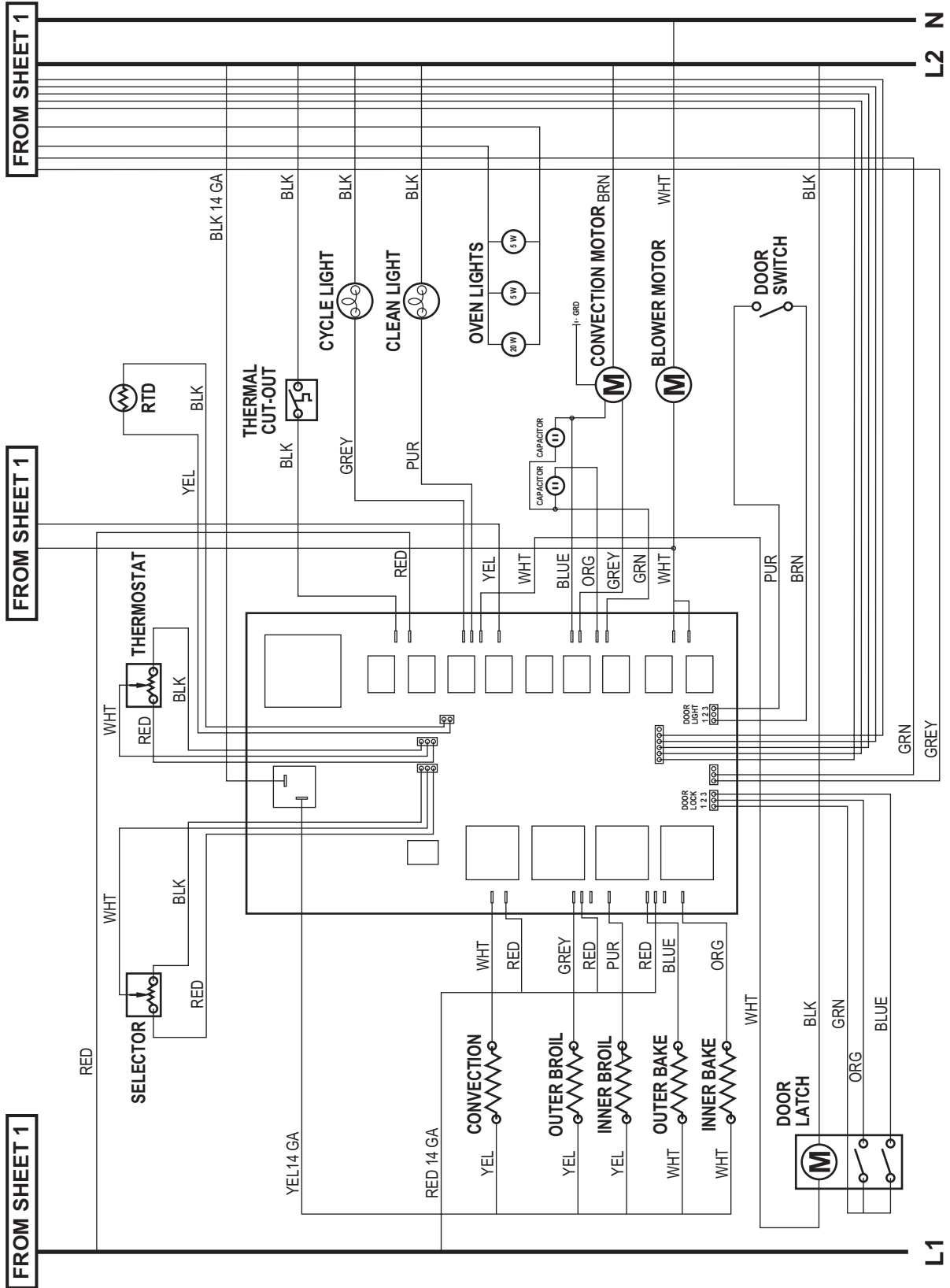

Professional Premiere Double Oven (Lower)

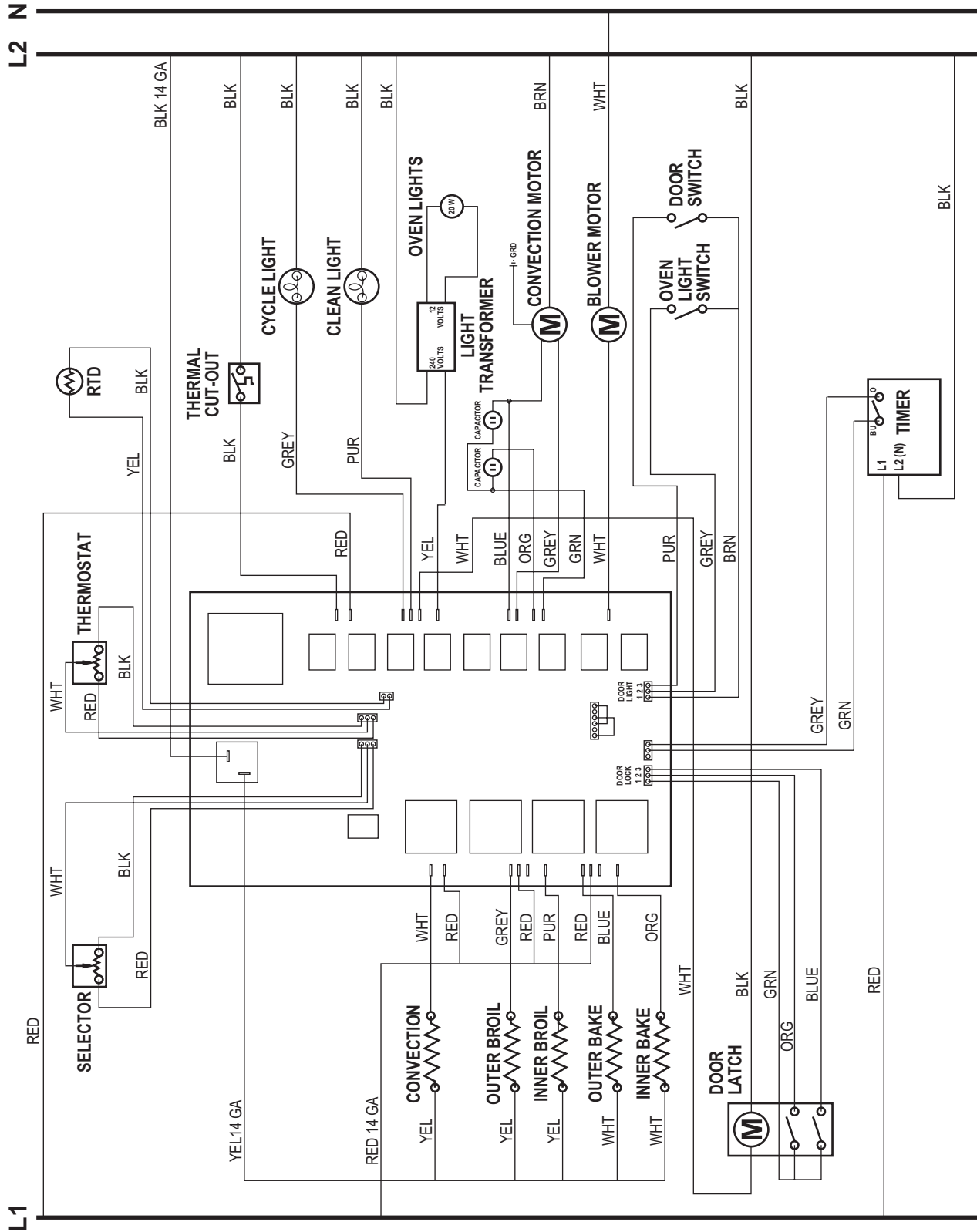

Designer Select Single Oven

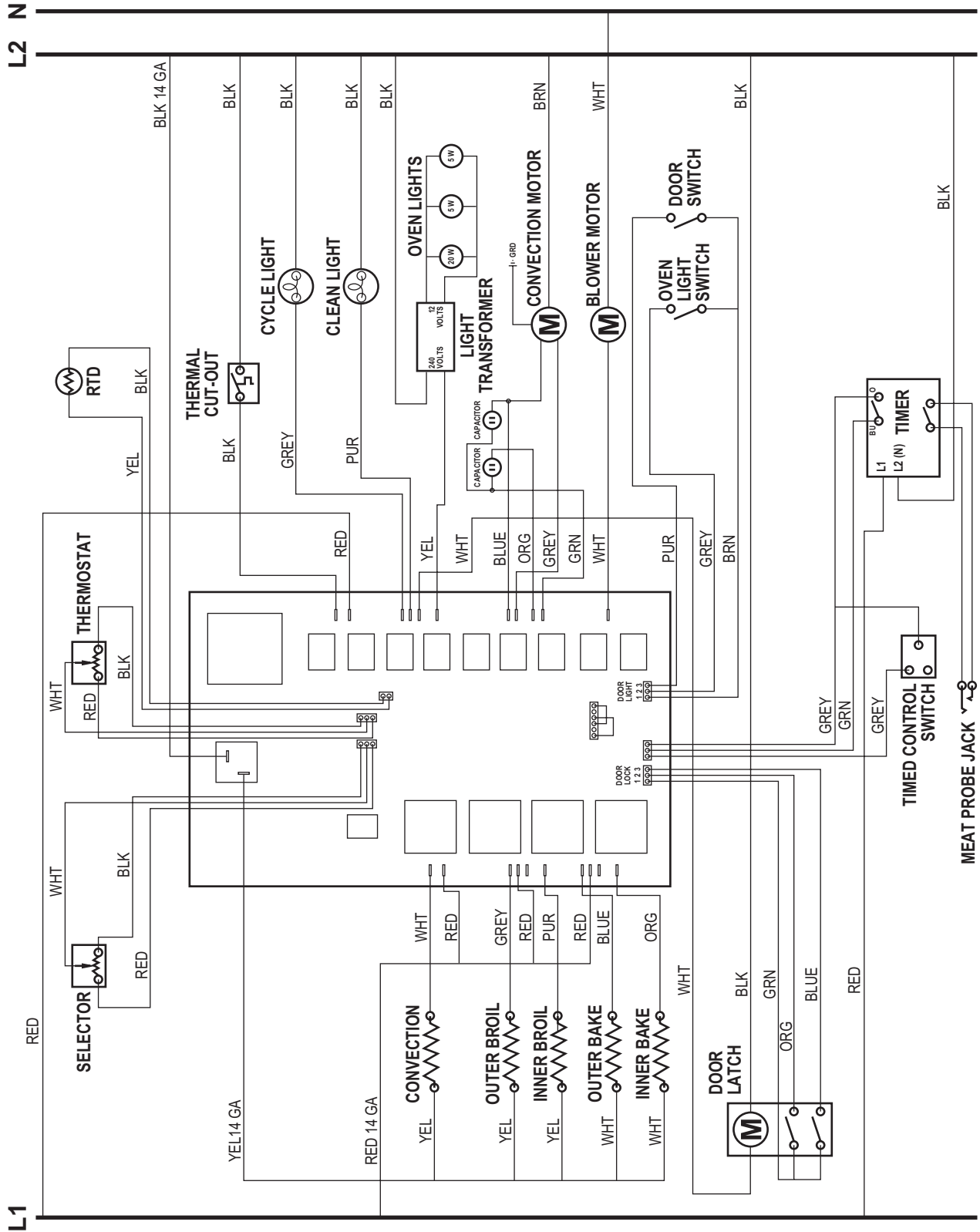

Designer Premiere Single Oven

L2 N

L1

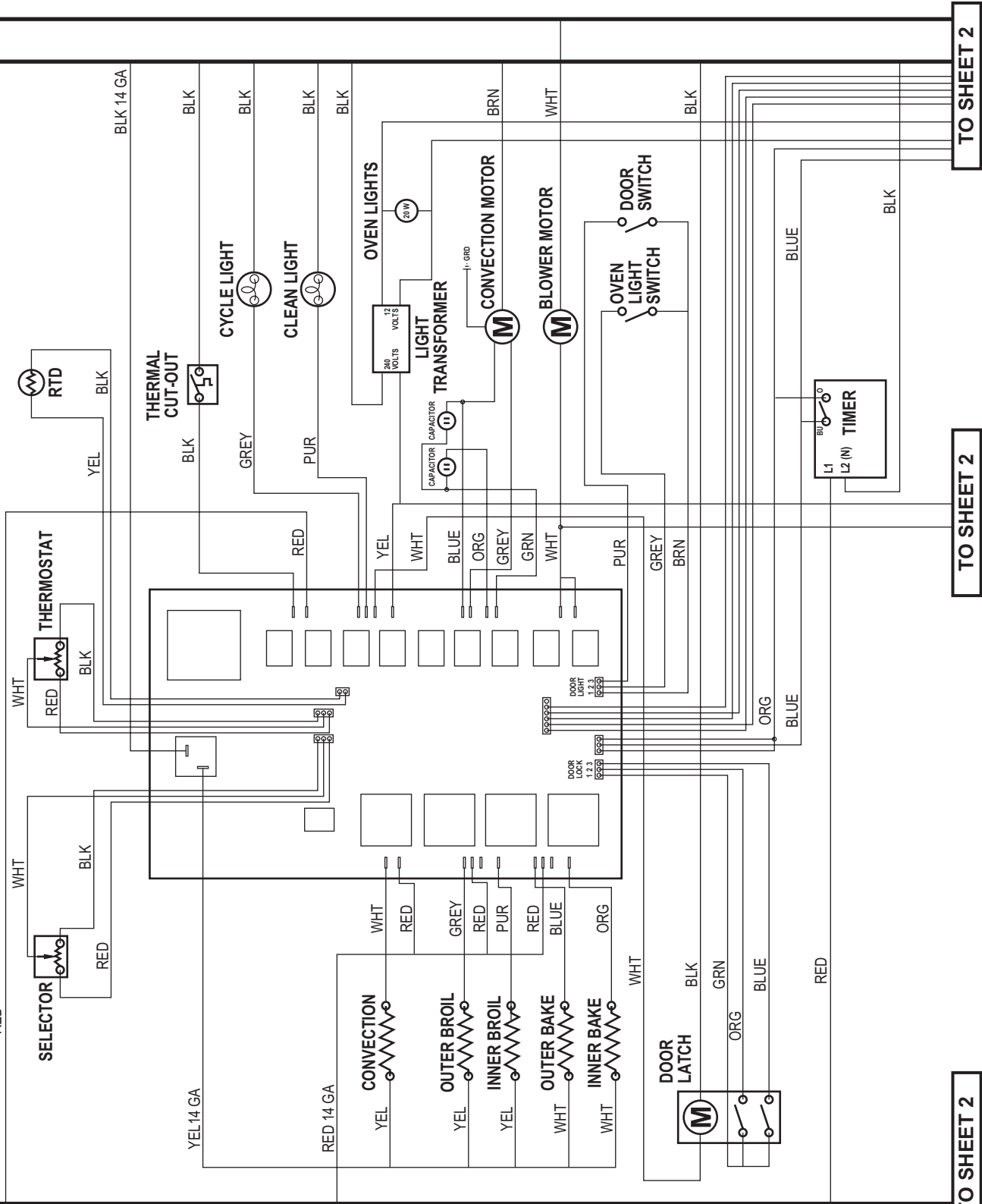

Designer Select Double Oven (Upper)

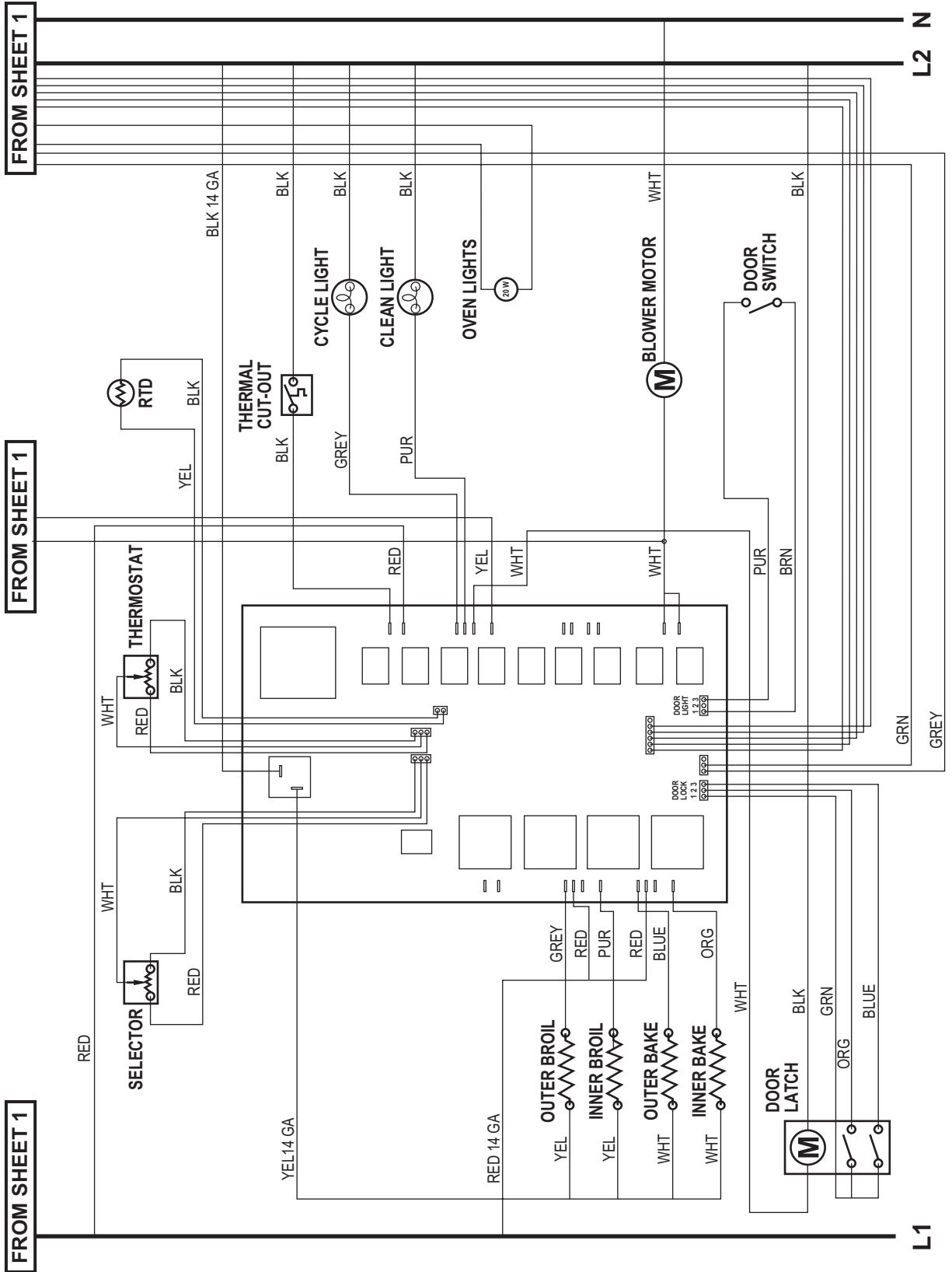

Designer Select Double Oven (Lower)

L2 N

L1

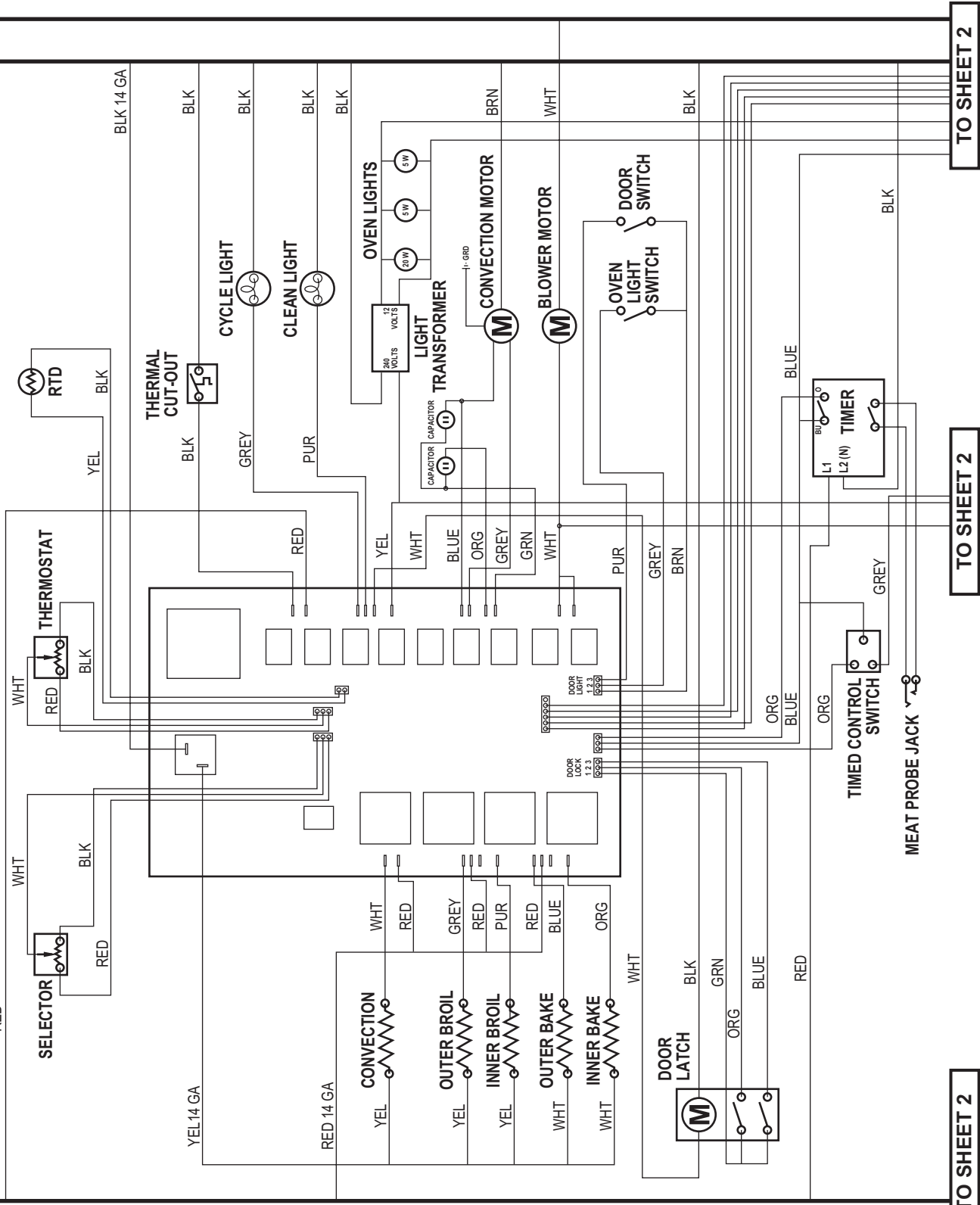

TO SHEET 2

TO SHEET 2

TO SHEET 2

Designer Premiere Double Oven (Upper)

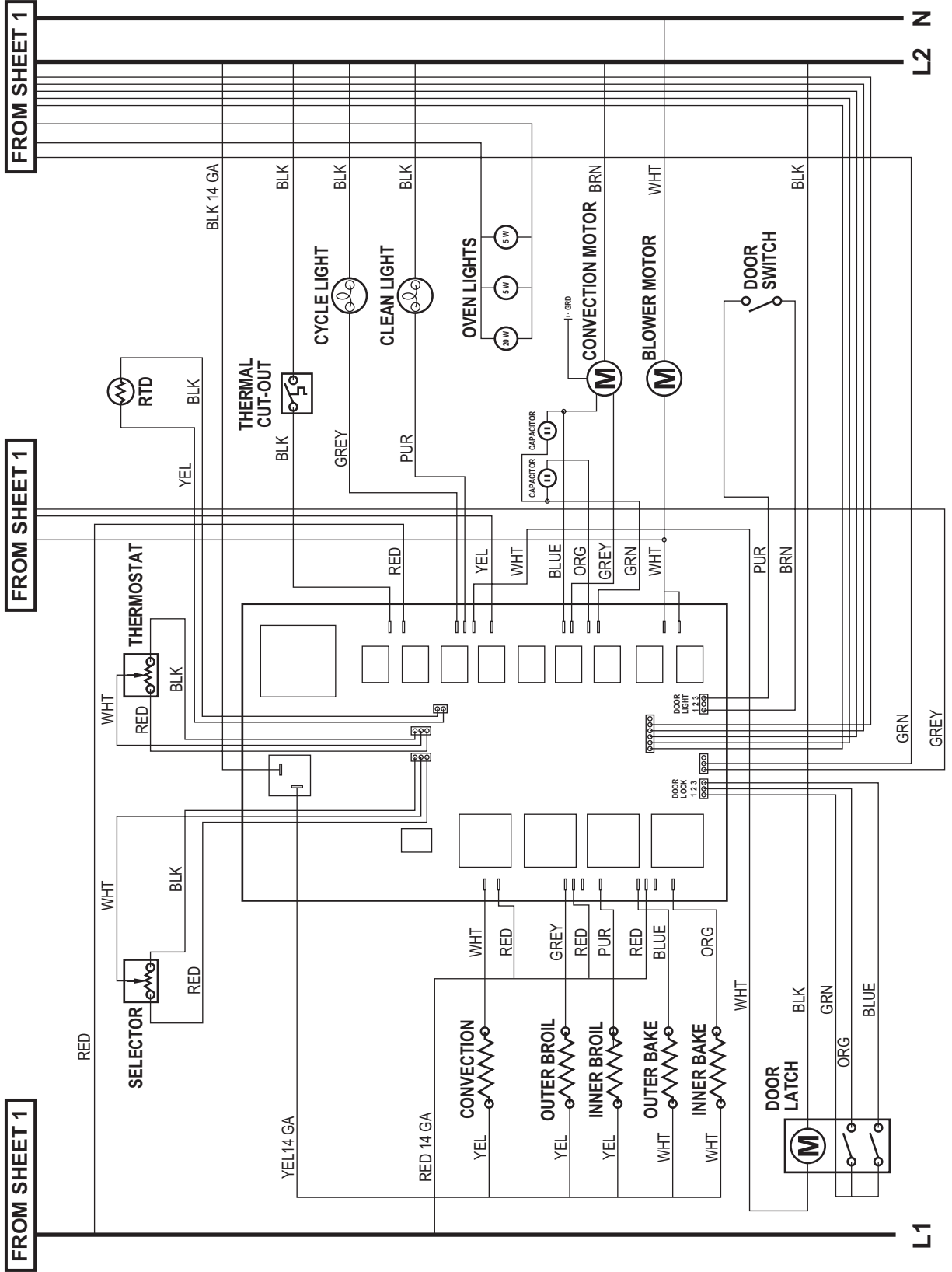

Designer Premiere Double Oven (Lower)

Technical Bulletin



Attention: Service Managers
√Service and Parts Managers

Date: August 2007

No: TC-0019A-SP

Page 1 of 1

Model(s): DEDO127, DEDO130, DEDO527, DEDO530,
DESO127, DESO130, DESO527, DESO530,
VEDO127, VEDO130, VEDO527, VEDO530,
VESO127, VESO130, VESO527, VESO530

Product
Cooking

Subject: Control board jumper kit and error codes for
mechanical control (knob control) Built-In Ovens listed above

Solution: **Mechanical Control Board Kit number 002406-000 contents:**

- 1 – Control Board – 000621-000
- 1 – Limiter Jumper – 000915-000
- 1 – Fan Motor Jumper – 001097-000

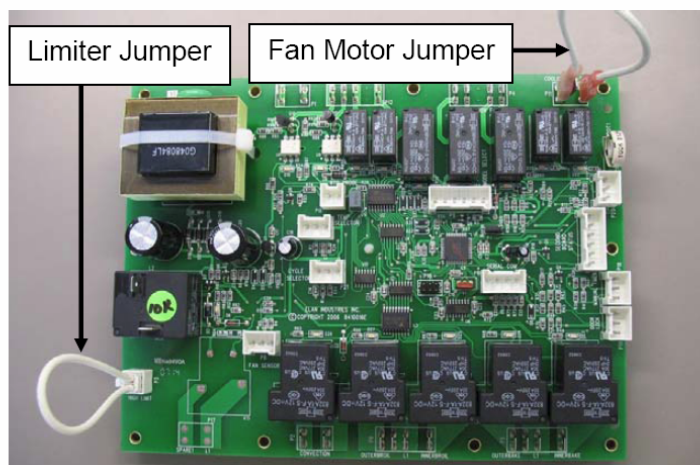

LED ERROR CODES

Latch error:

- Cycle light – OFF
- Clean light – 1 second ON, 1 second OFF

RTD (oven probe) error:

- Cycle light – 1 second ON, 1 second OFF
- Clean light – OFF

Model error:

- Cycle light – 1 second ON, 1 second OFF, 1 second ON, 4 seconds OFF
- Clean light – ON

Cooling fan error:

- Cycle light – 3 flashes
- Clean light – ON

High limit error:

- Cycle light – 4 flashes
- Clean light – ON

On all DEDO – VEDO 127, 130, 527 and 530 models, the Main Control Board was changed to use a low Voltage circuit protection wired directly through the board. Earlier version had the High Limit protector wired in Series with the L2 power connection on the control board. Pages 70, 72, 74, 75, 78, 79, 82, 84, 86, 87, 90 and 91 show this configuration. The Current configuration has the High Limiter wired directly to the board via a 2-pin Molex Connector. This is shown on page 71, 73, 76, 77, 80, 81, 83, 85, 88, 89, 92 and 93.

When replacing the old board that had the High Limit Protector wired in series with L2 on the board, a Limiter Jumper is required in order for the unit to function. The Bulletin above is for those models. If the unit you are working on has the Limiter wired direct to the board, then only order the board.

Differences between Old style and new Style Board

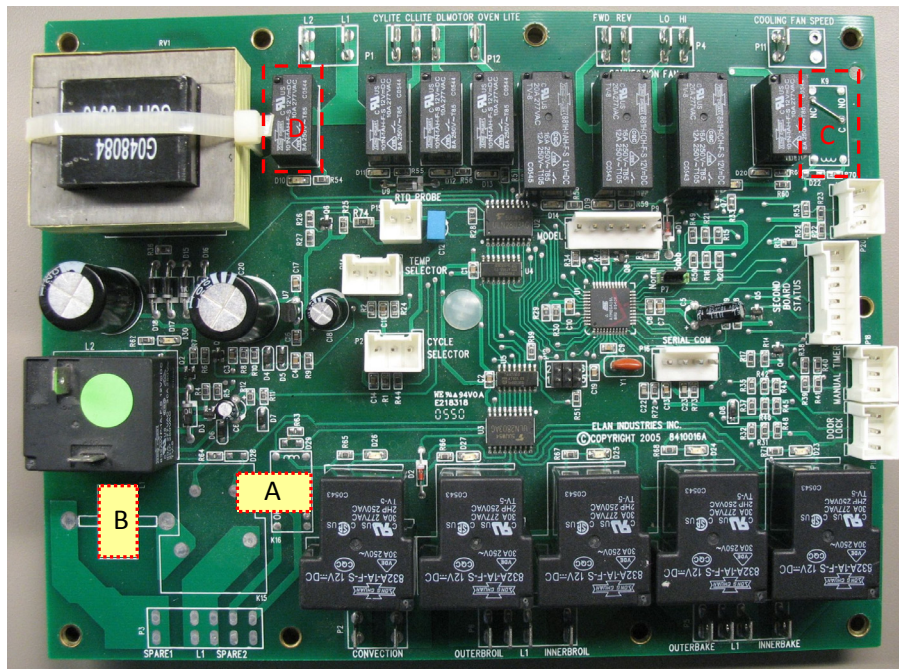

Original Board

- No Fan Sensor Connection on Board (A)
- No High Limit connection on Board (B)
- Only one speed fan connection on board (C)
- Additional Power relay on board (D)

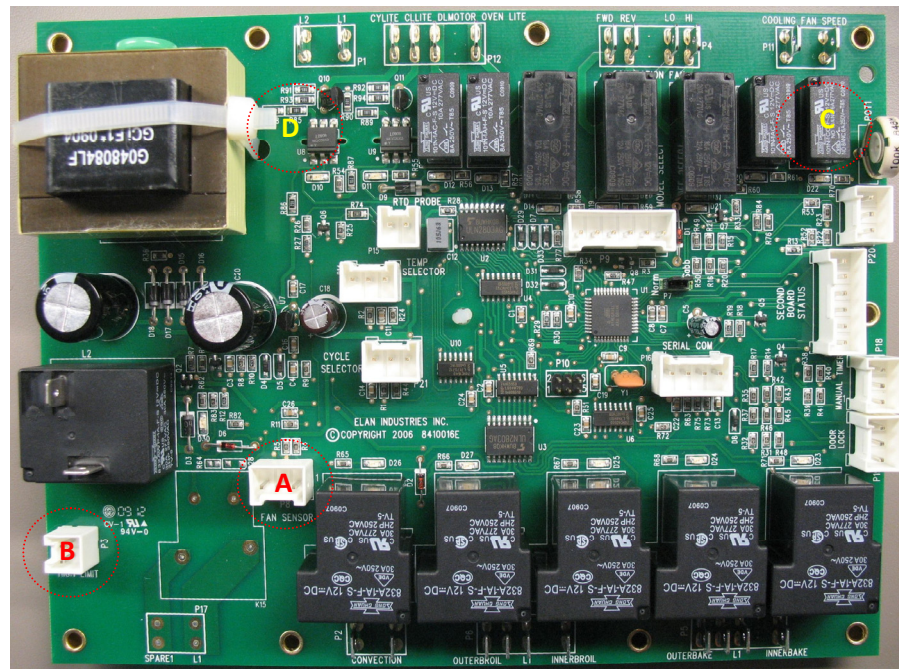

Current Board

- Fan Sensor Connection on Board (A)
- High Limit connection on Board (B)
- Two speed fan connection on board (C)
- Additional Power relay on board removed (D)

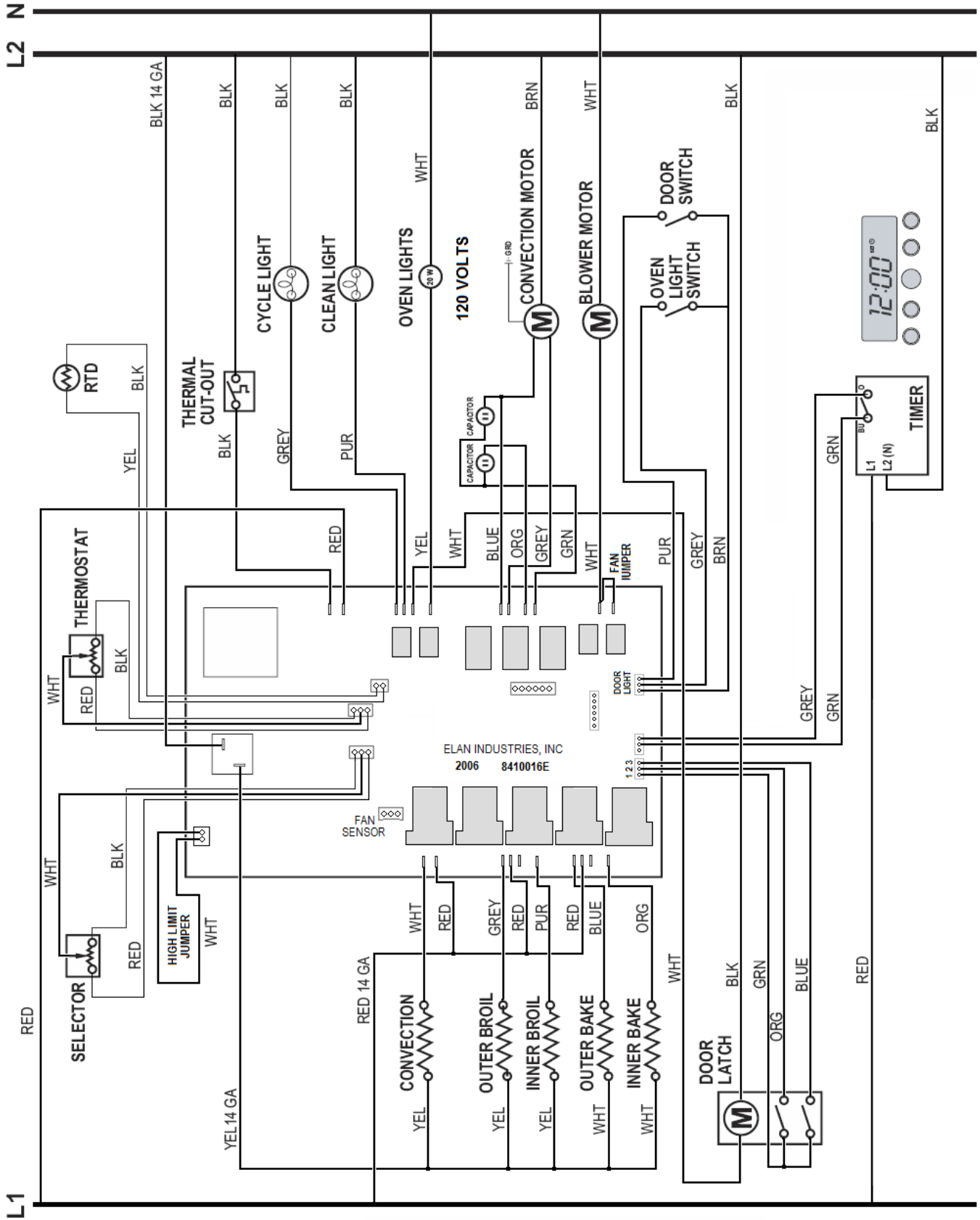

Professional Select Single Oven

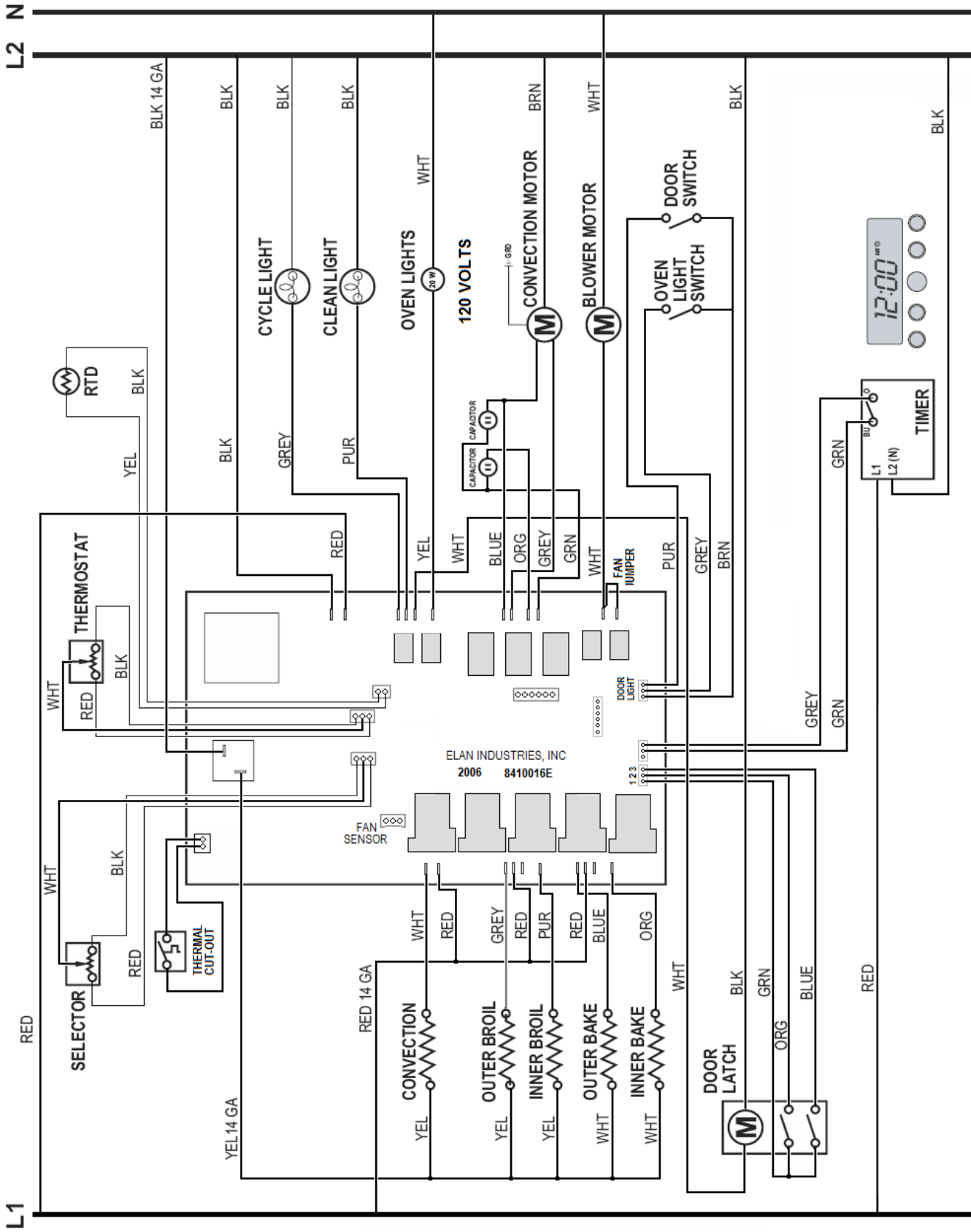

Professional Select Single Oven

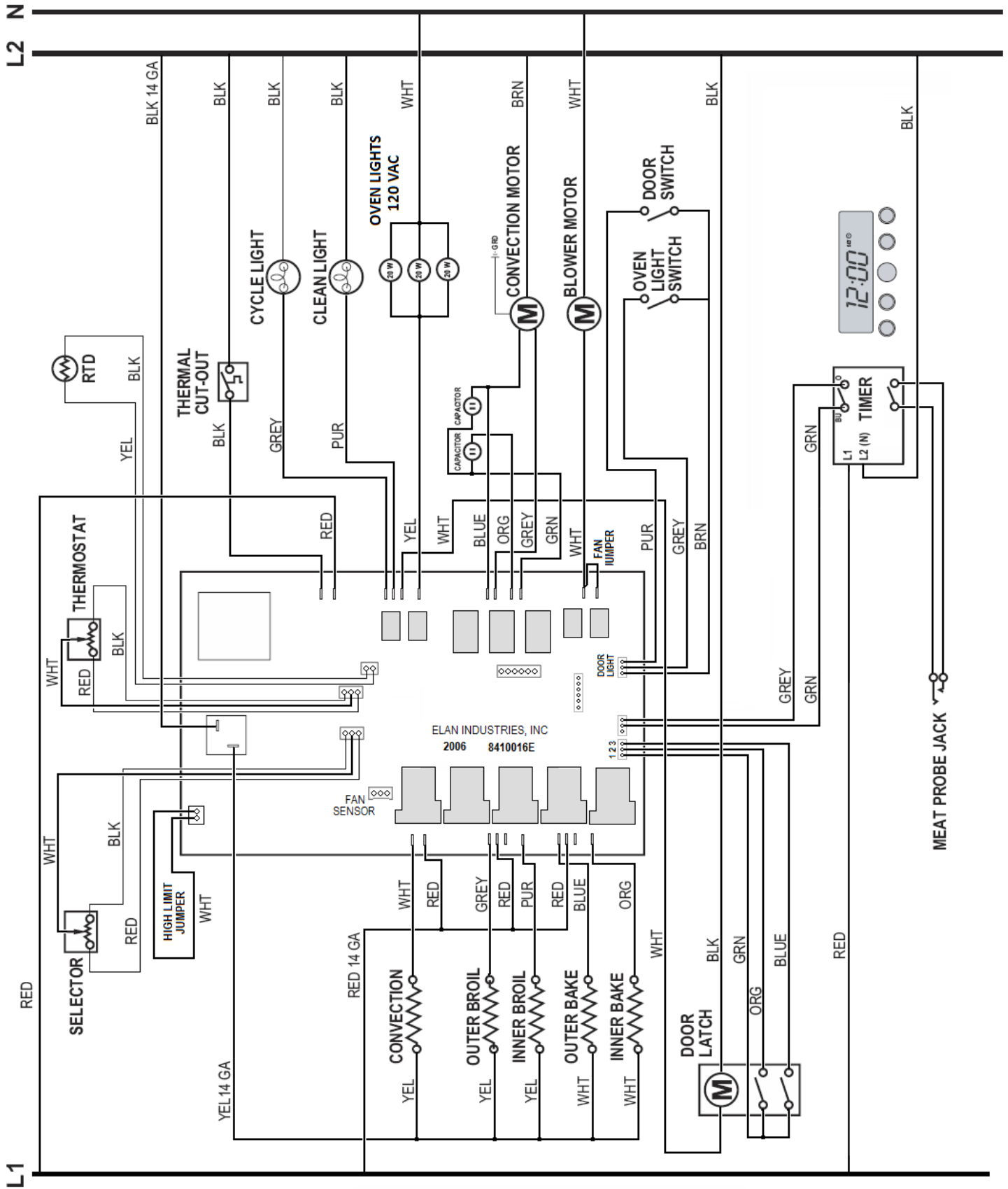

Professional Premiere Single Oven

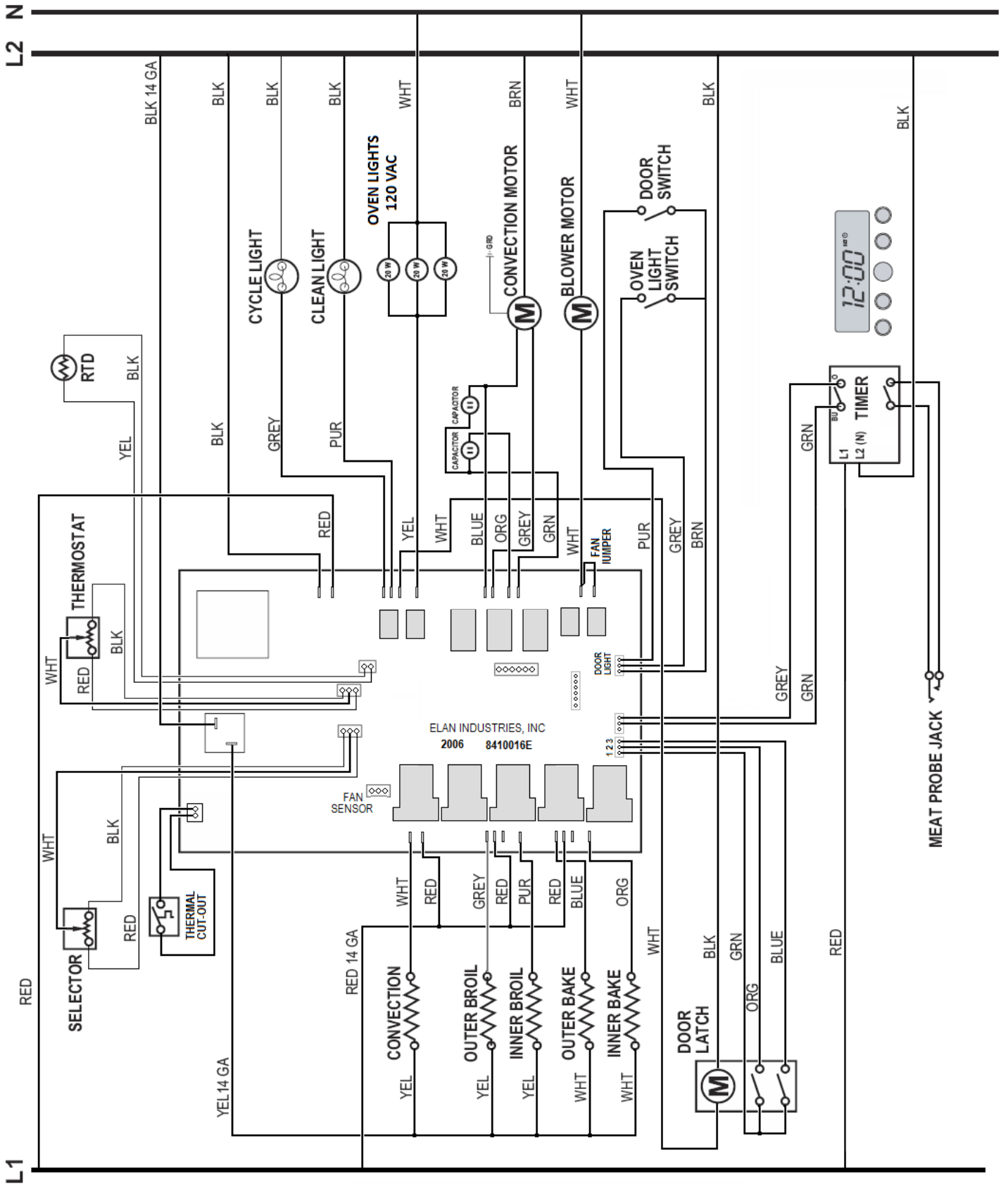

Professional Premiere Single Oven

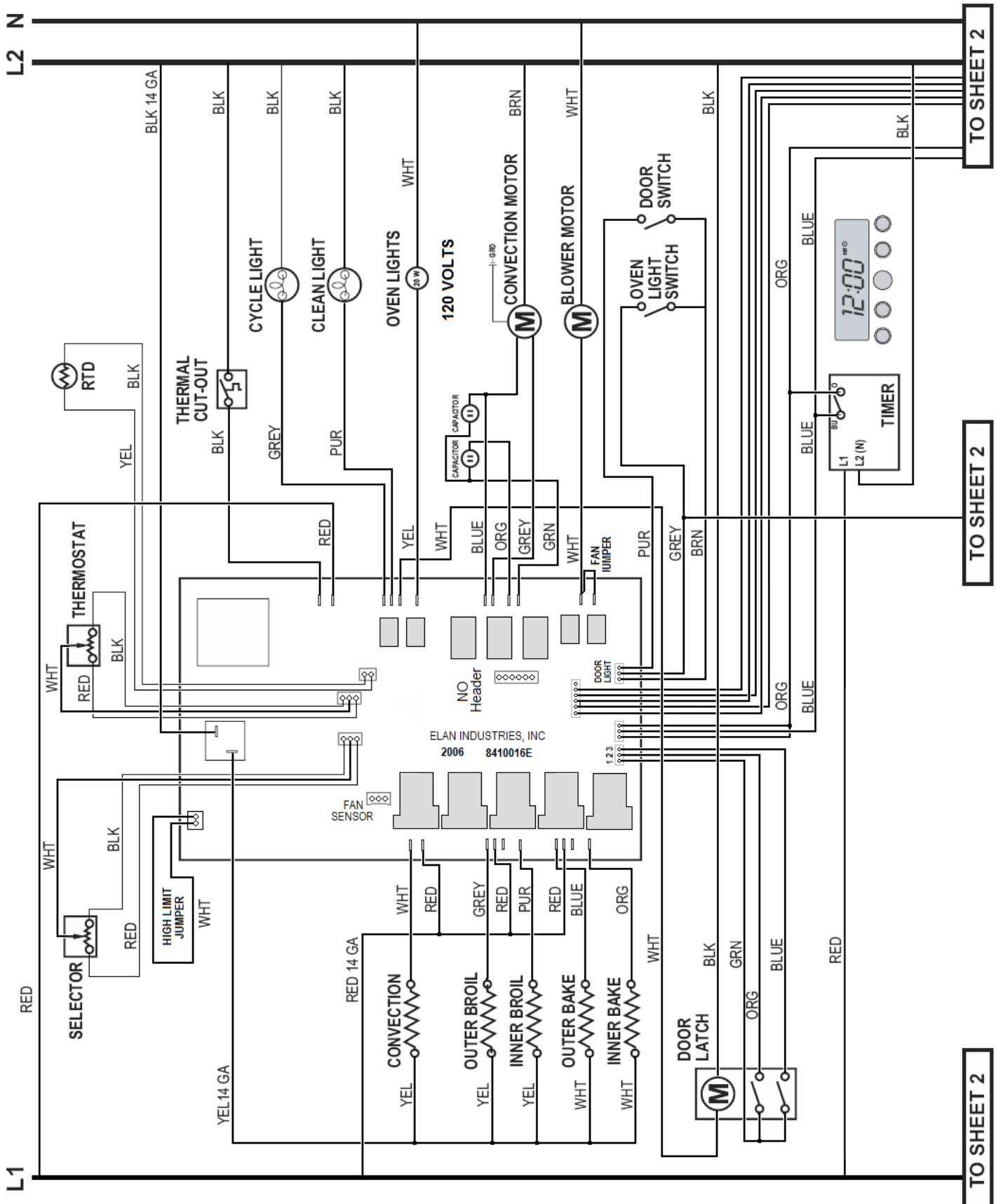

TO SHEET 2

TO SHEET 2

Professional Select Double Oven (Upper)

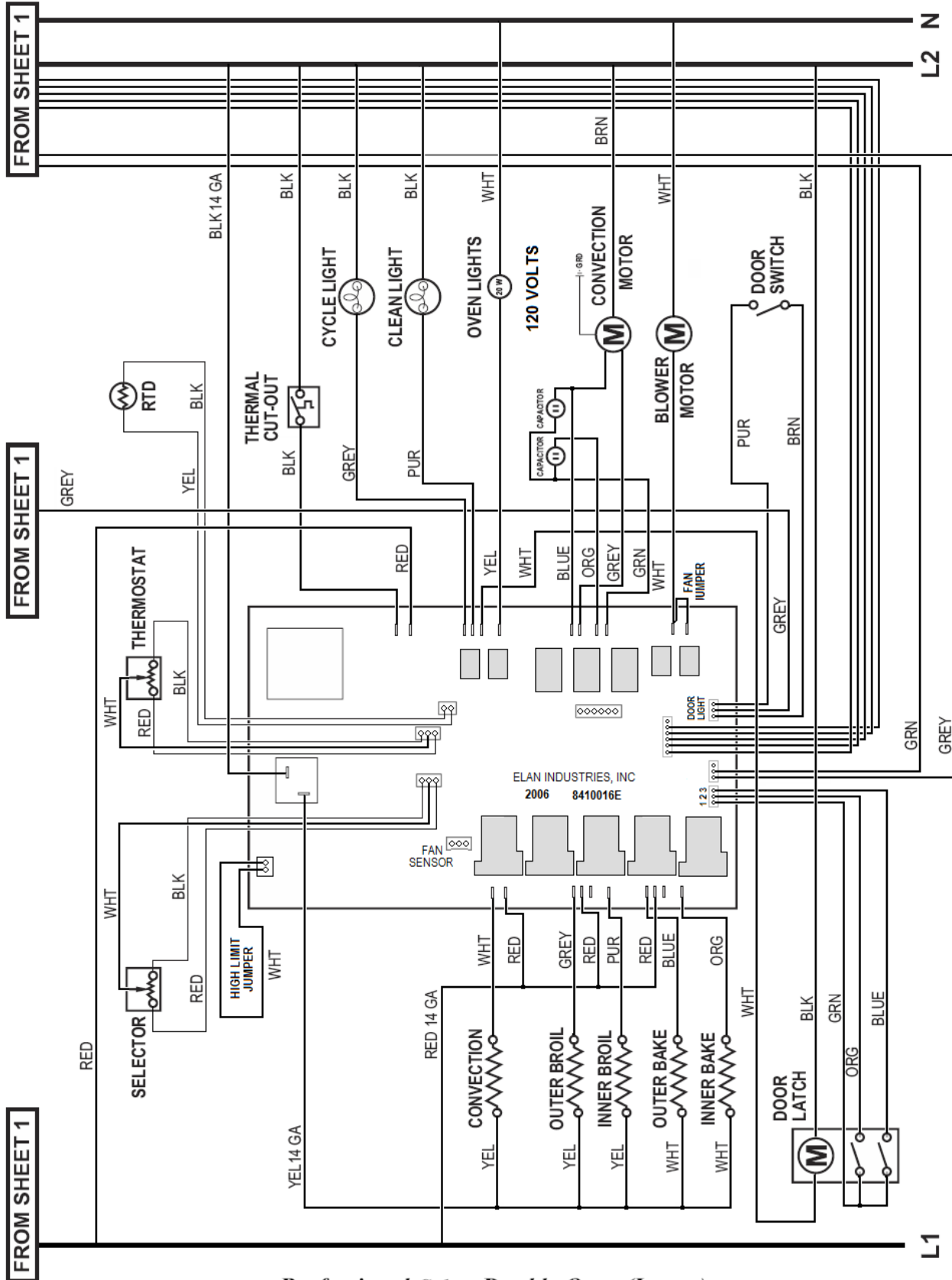

Professional Select Double Oven (Lower)

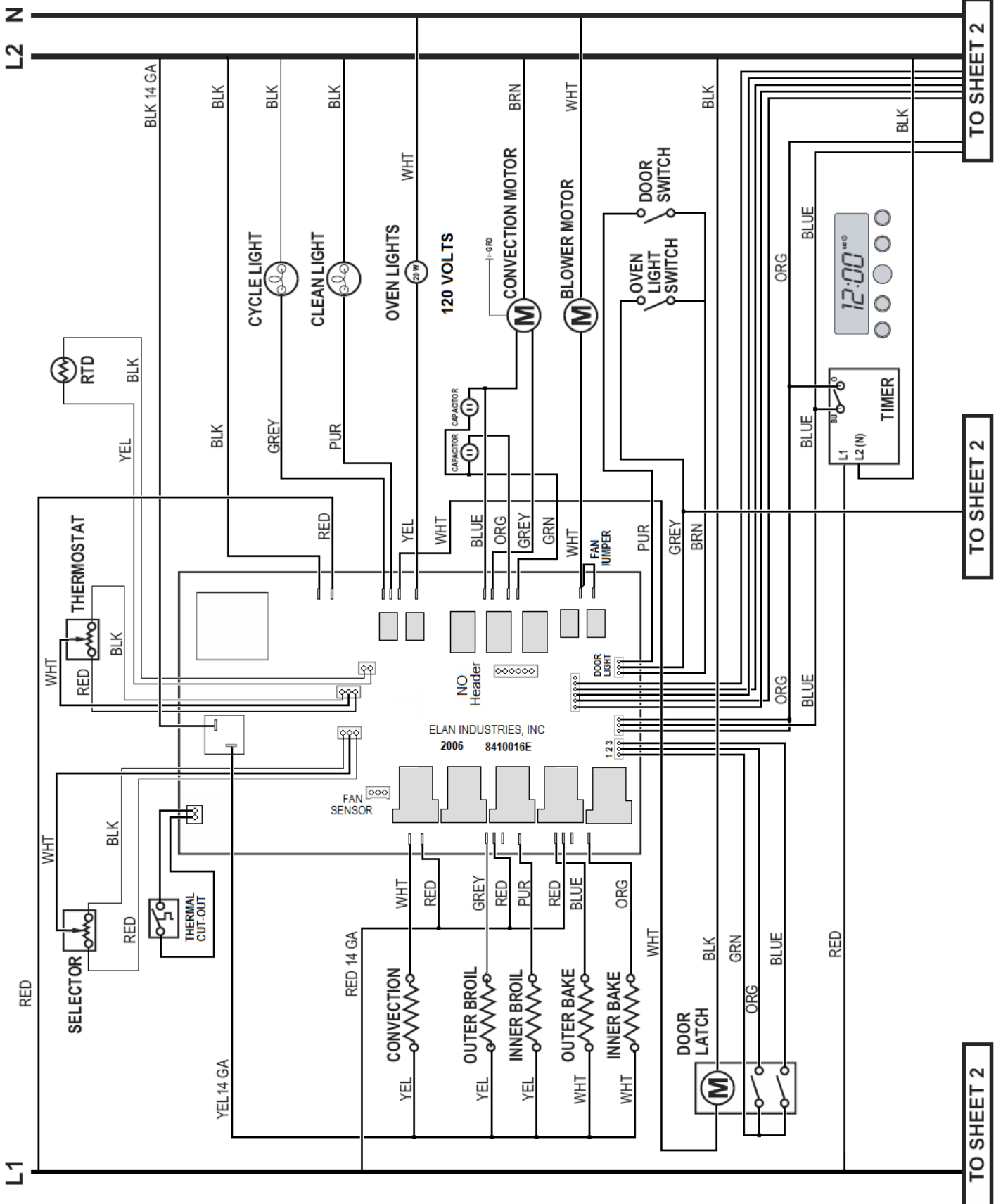

Professional Select Double Oven (Upper)

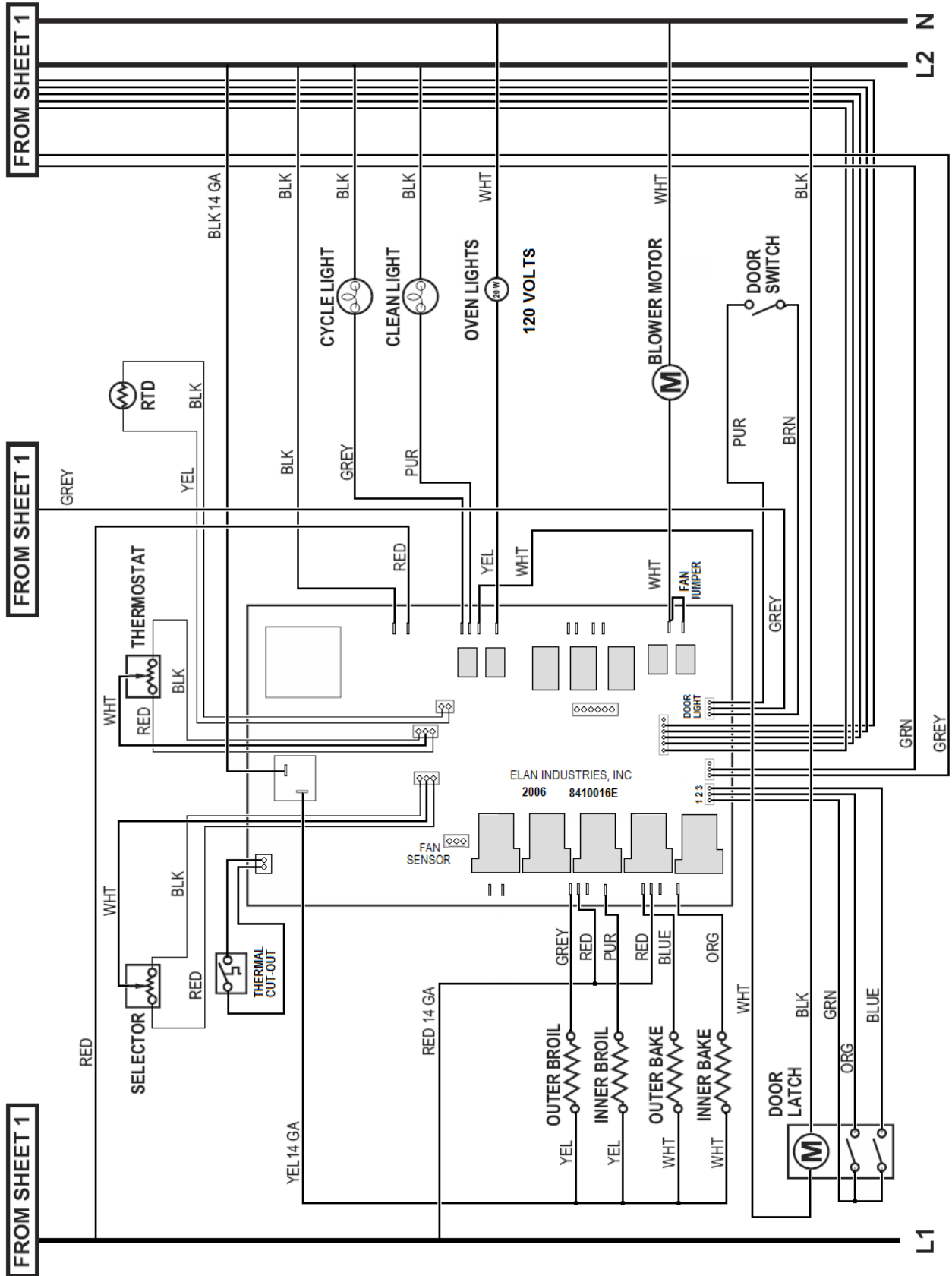

Professional Select Double Oven (Lower)

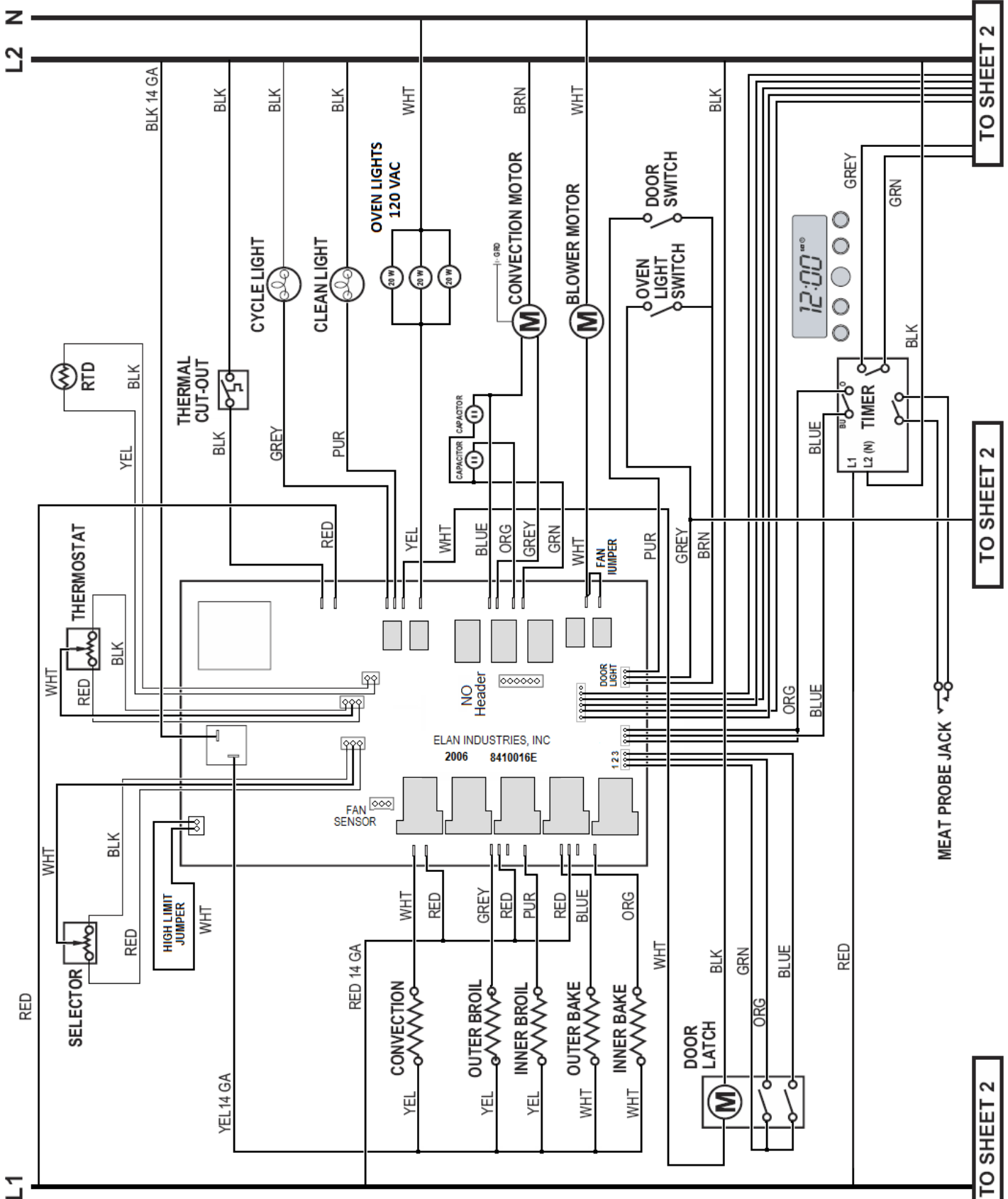

TO SHEET 2

TO SHEET 2

TO SHEET 2

Professional Premiere Double Oven (Upper)

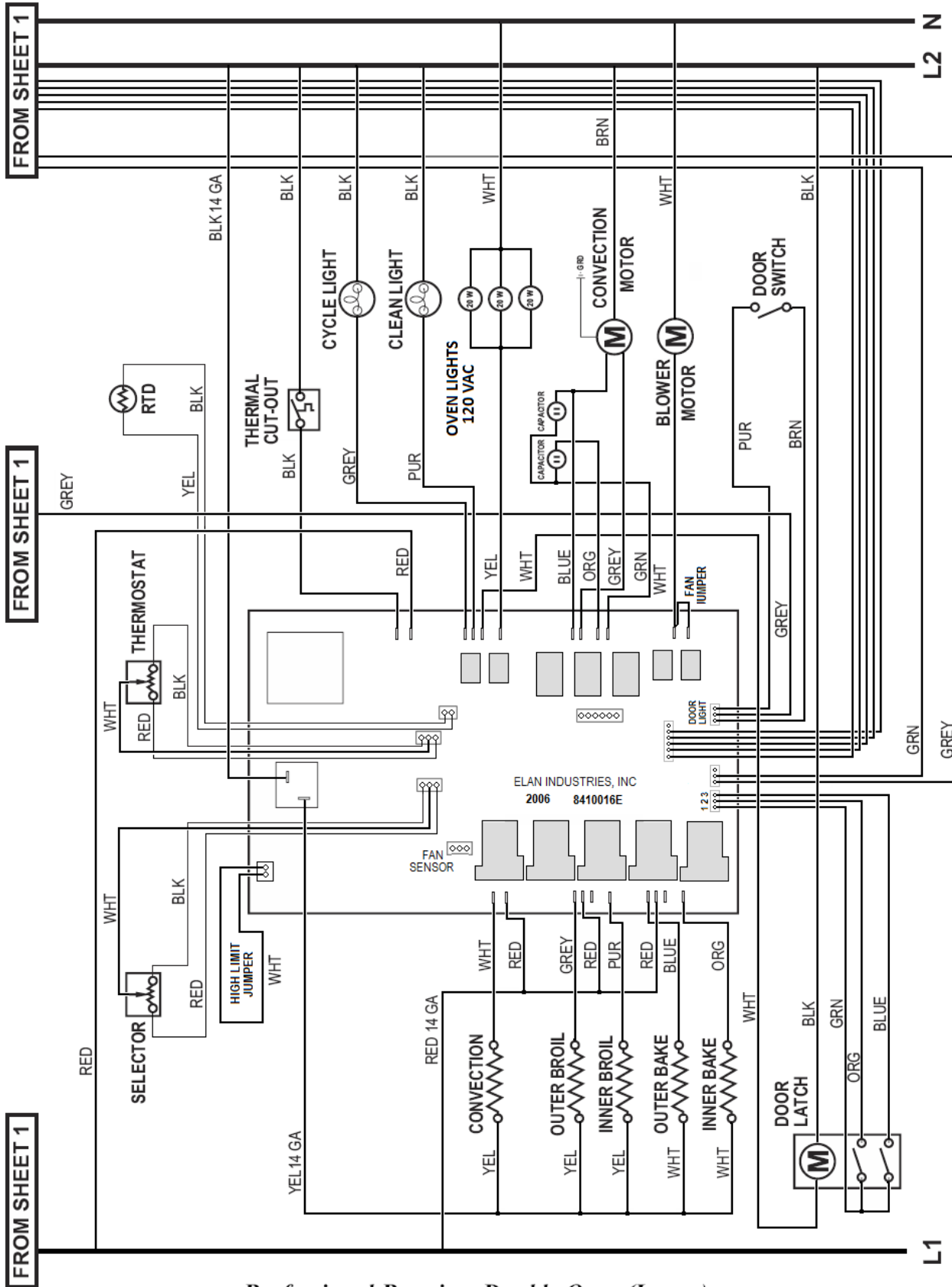

Professional Premiere Double Oven (Lower)

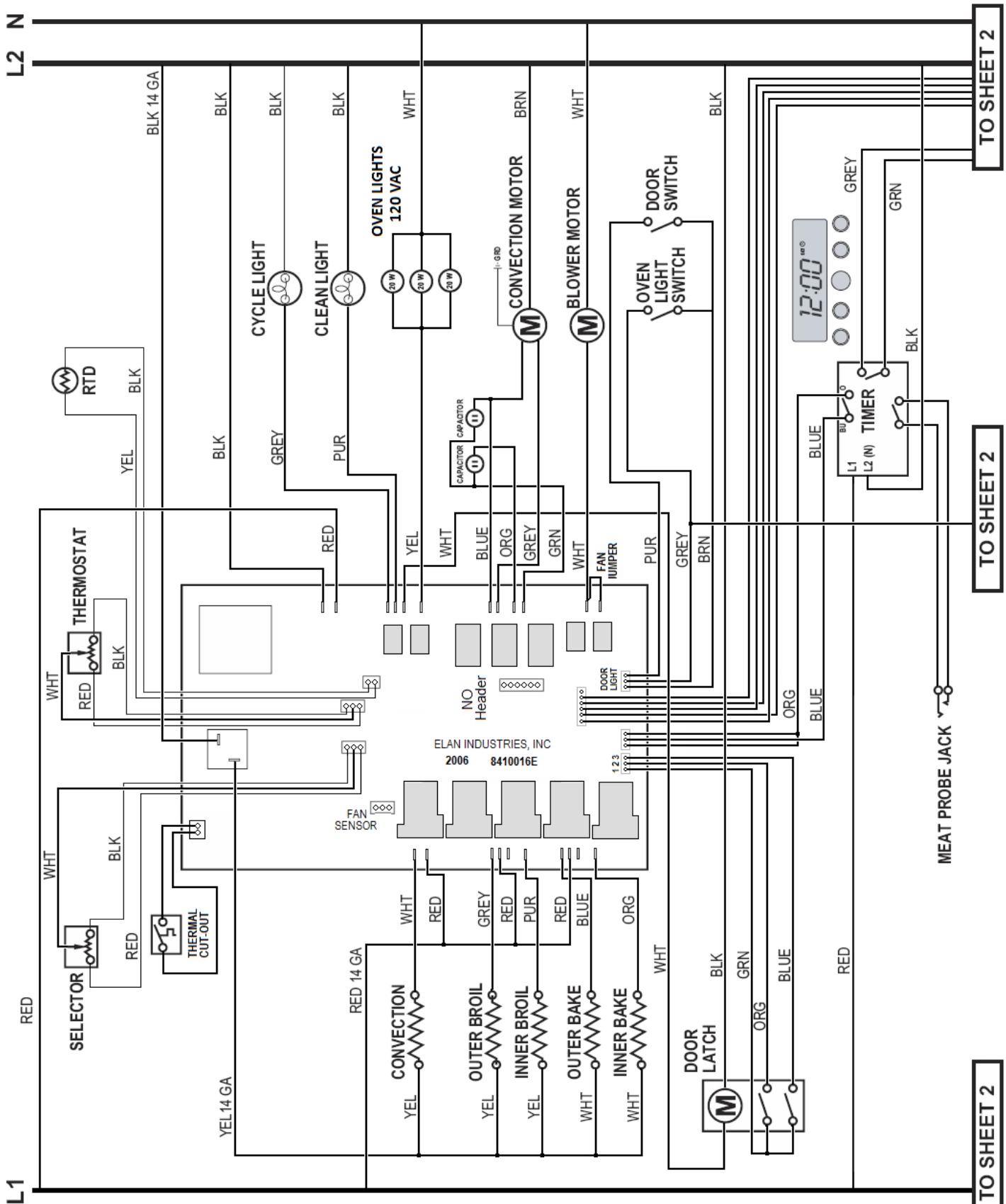

Professional Premiere Double Oven (Upper)

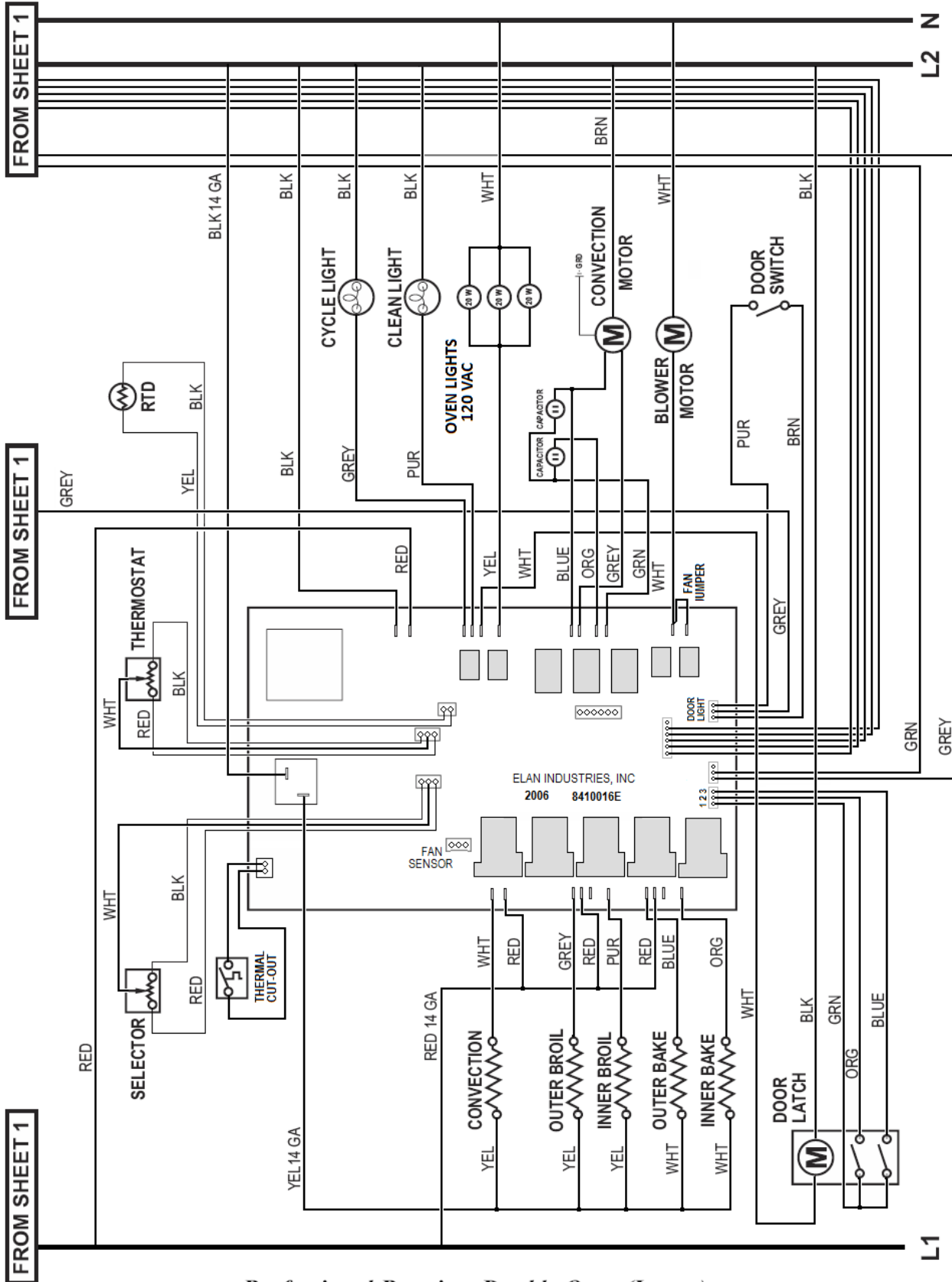

Professional Premiere Double Oven (Lower)

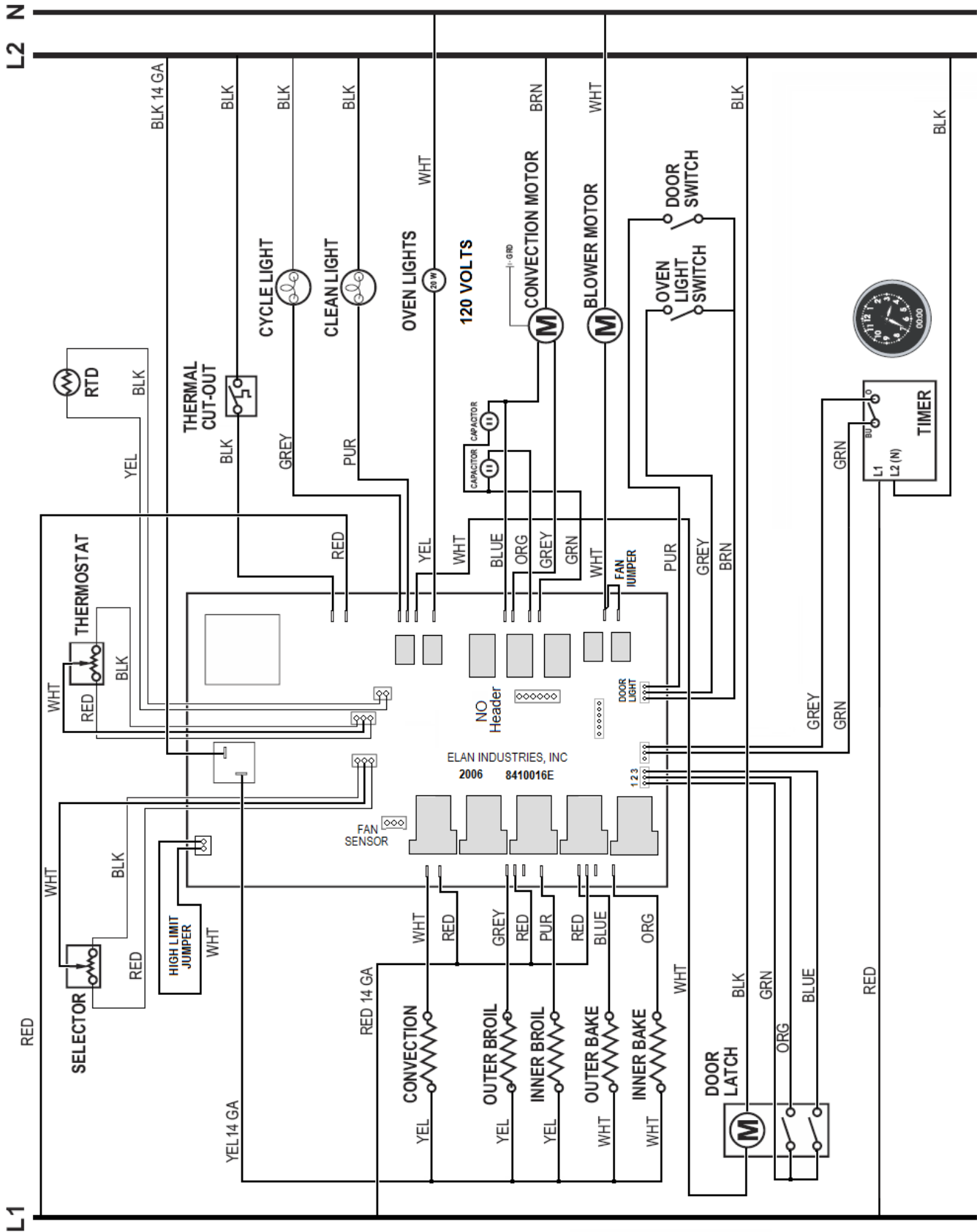

Designer Select Single Oven

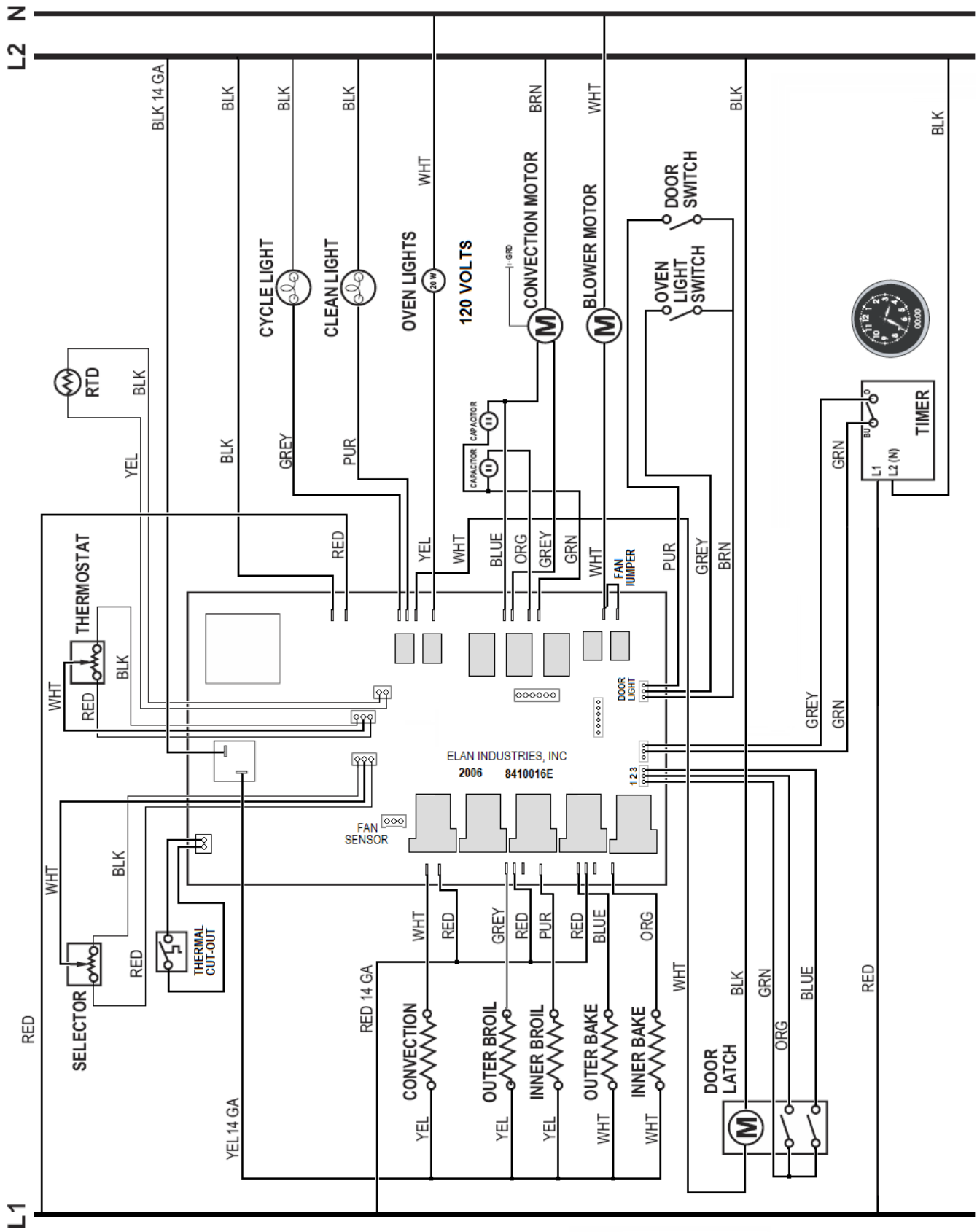

Designer Select Single Oven

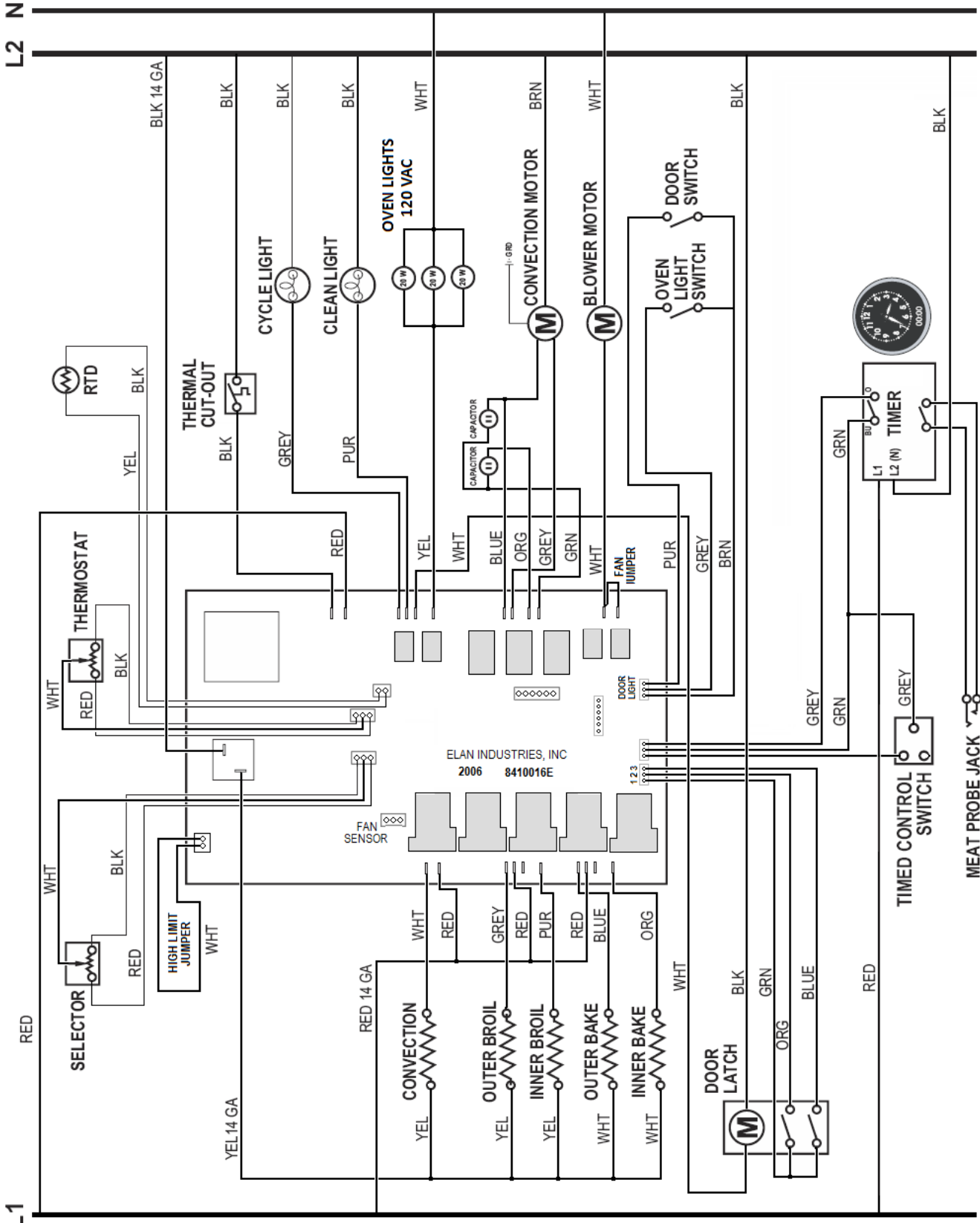

Designer Premiere Single Oven

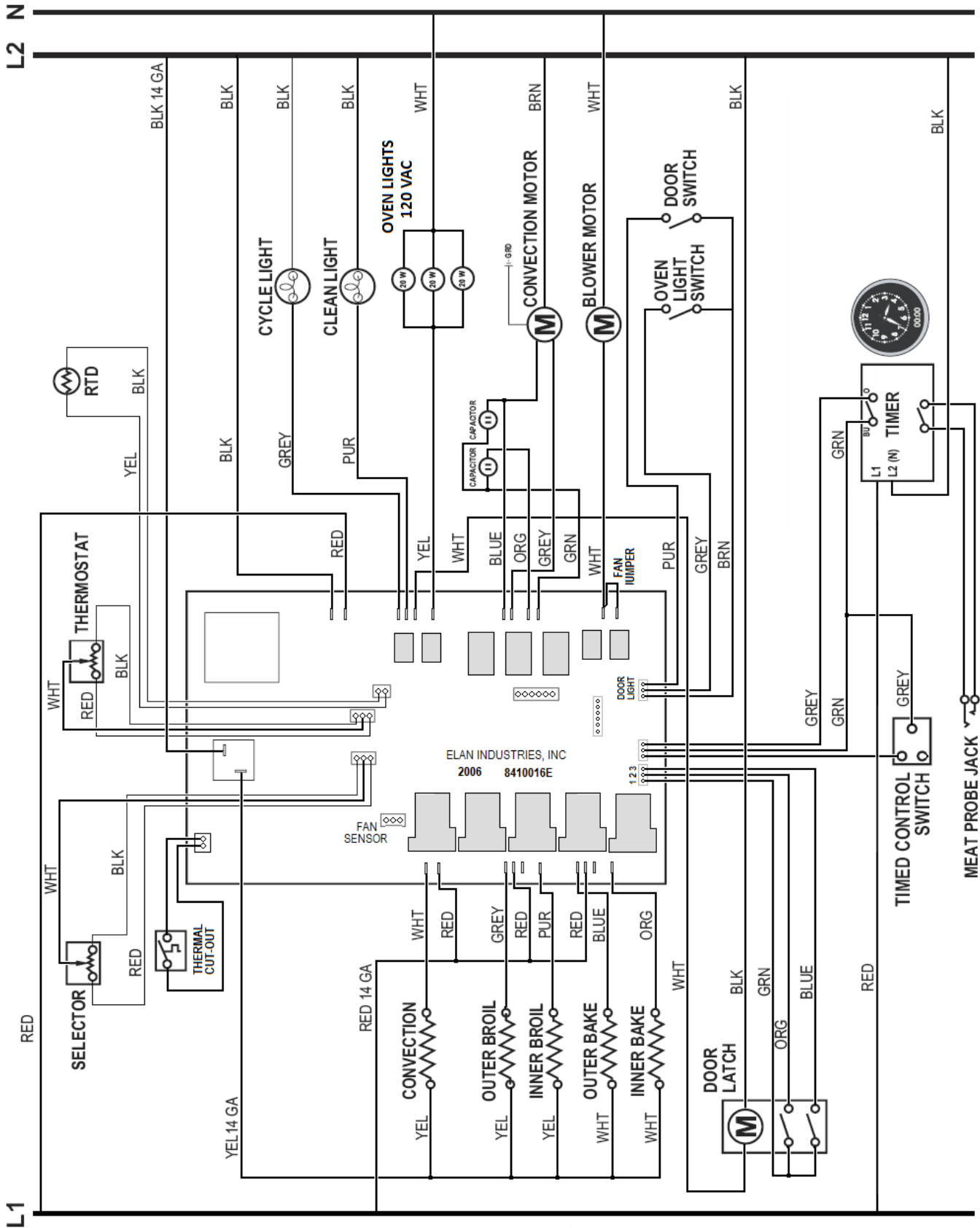

Designer Premiere Single Oven

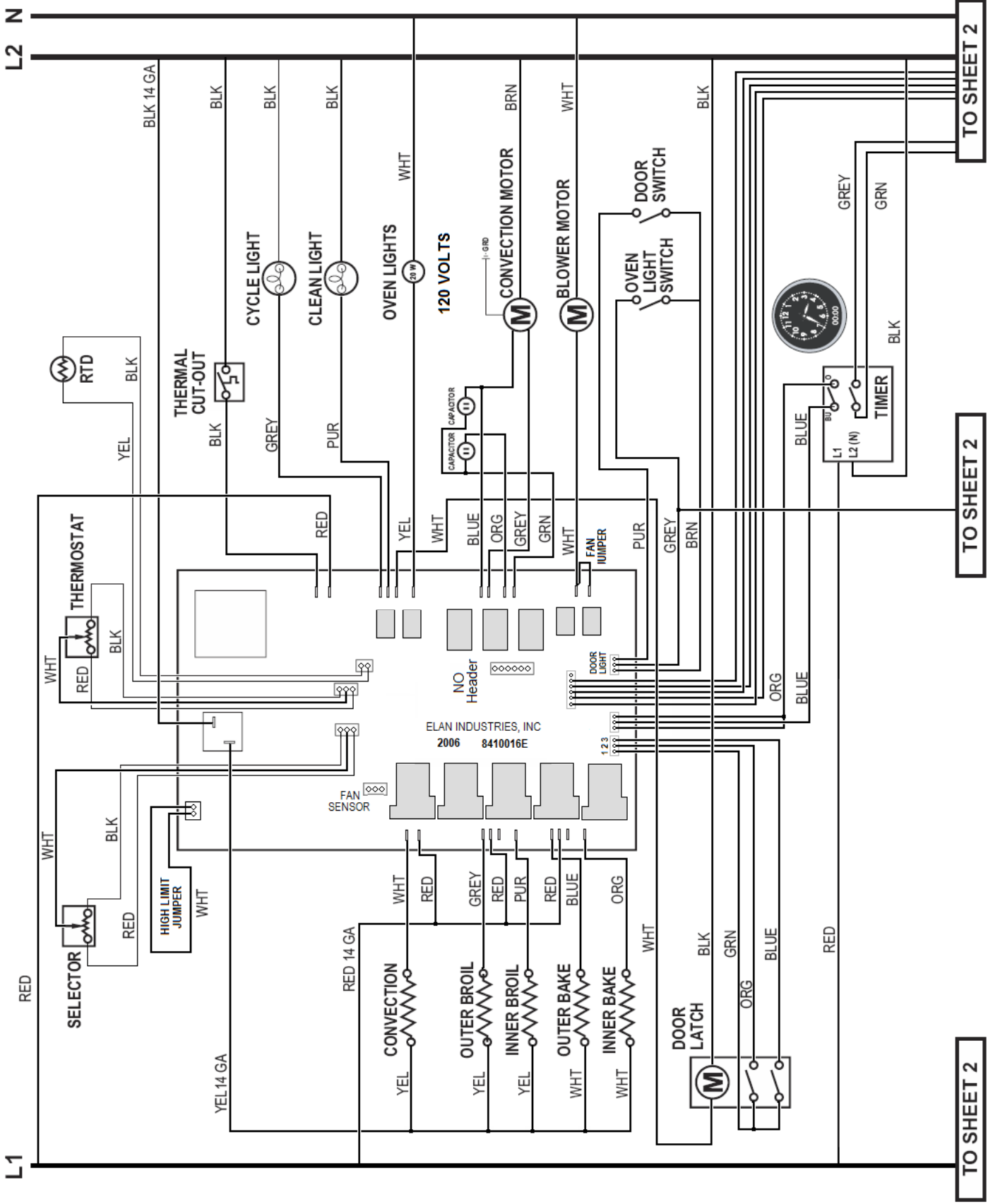

Designer Select Double Oven (Upper)

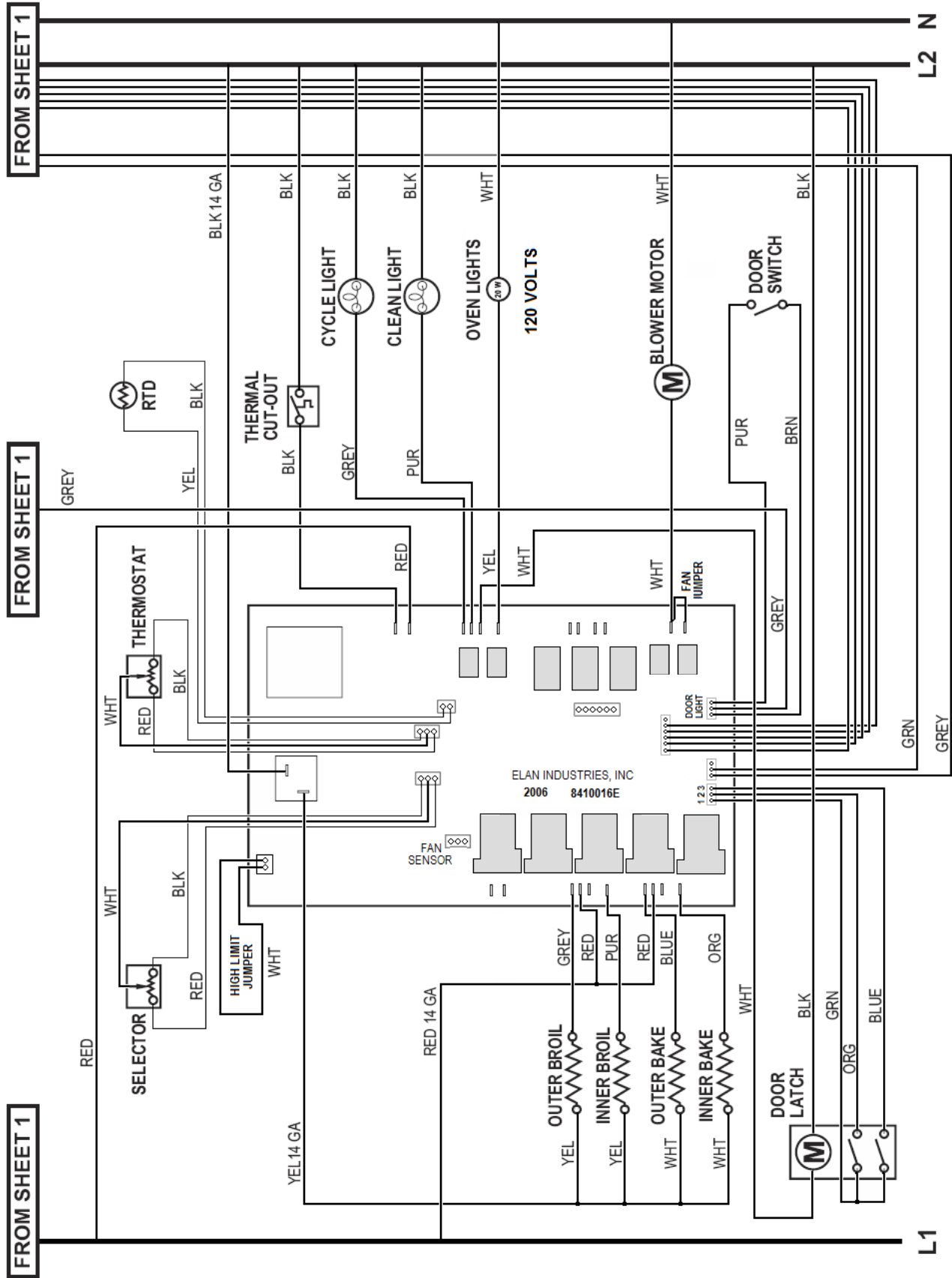

Designer Select Double Oven (Lower)

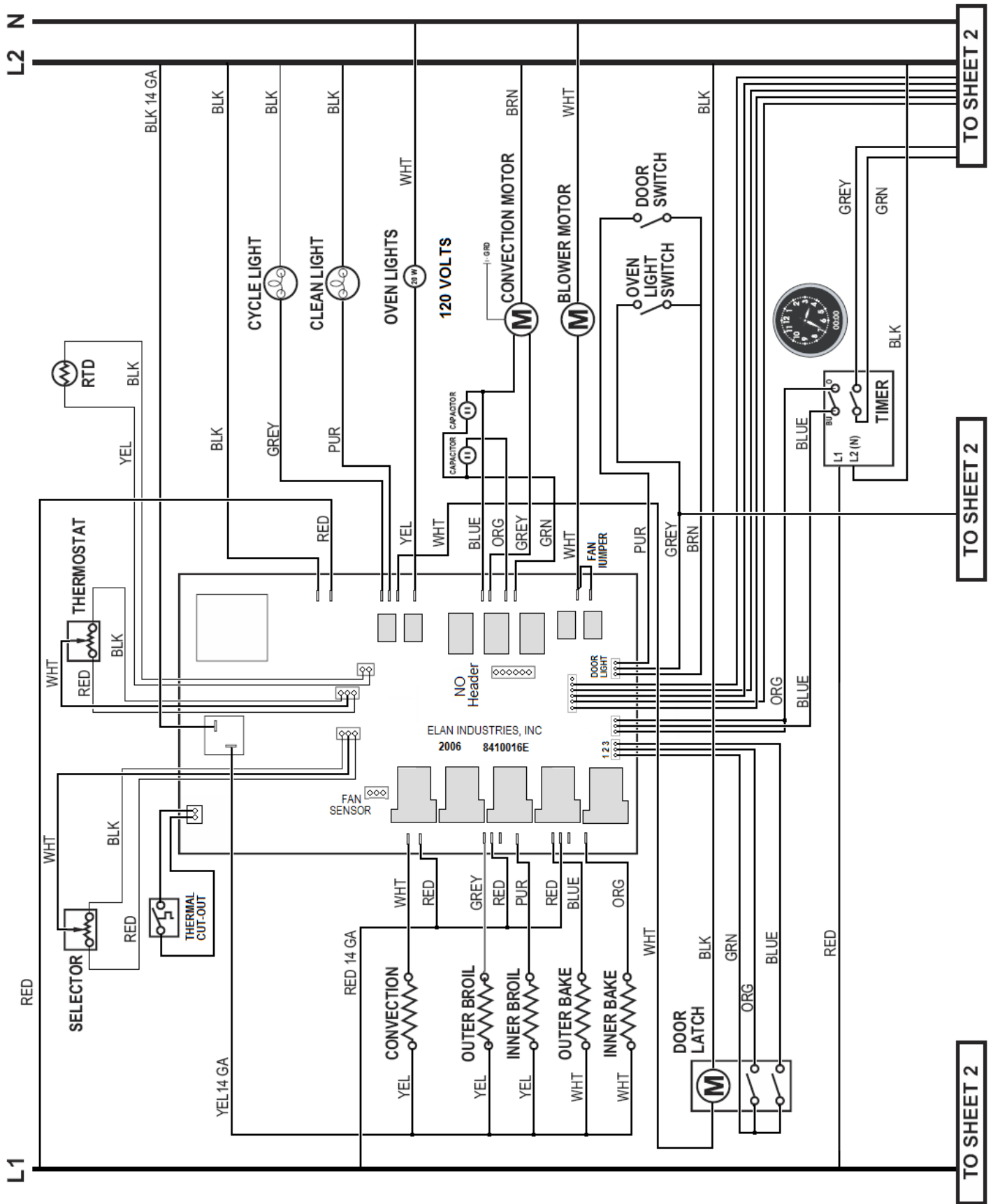

Designer Select Double Oven (Upper)

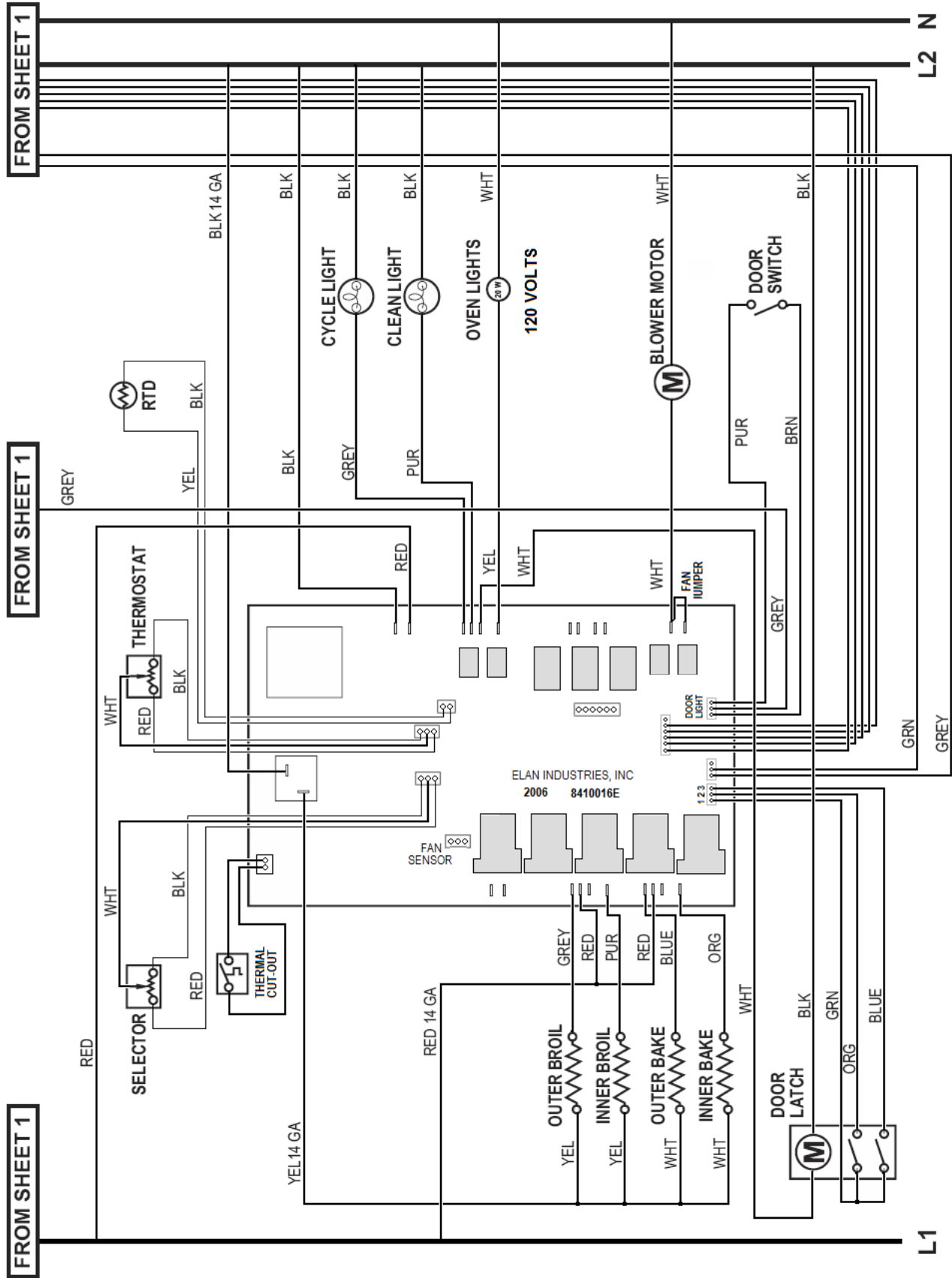

Designer Select Double Oven (Lower)

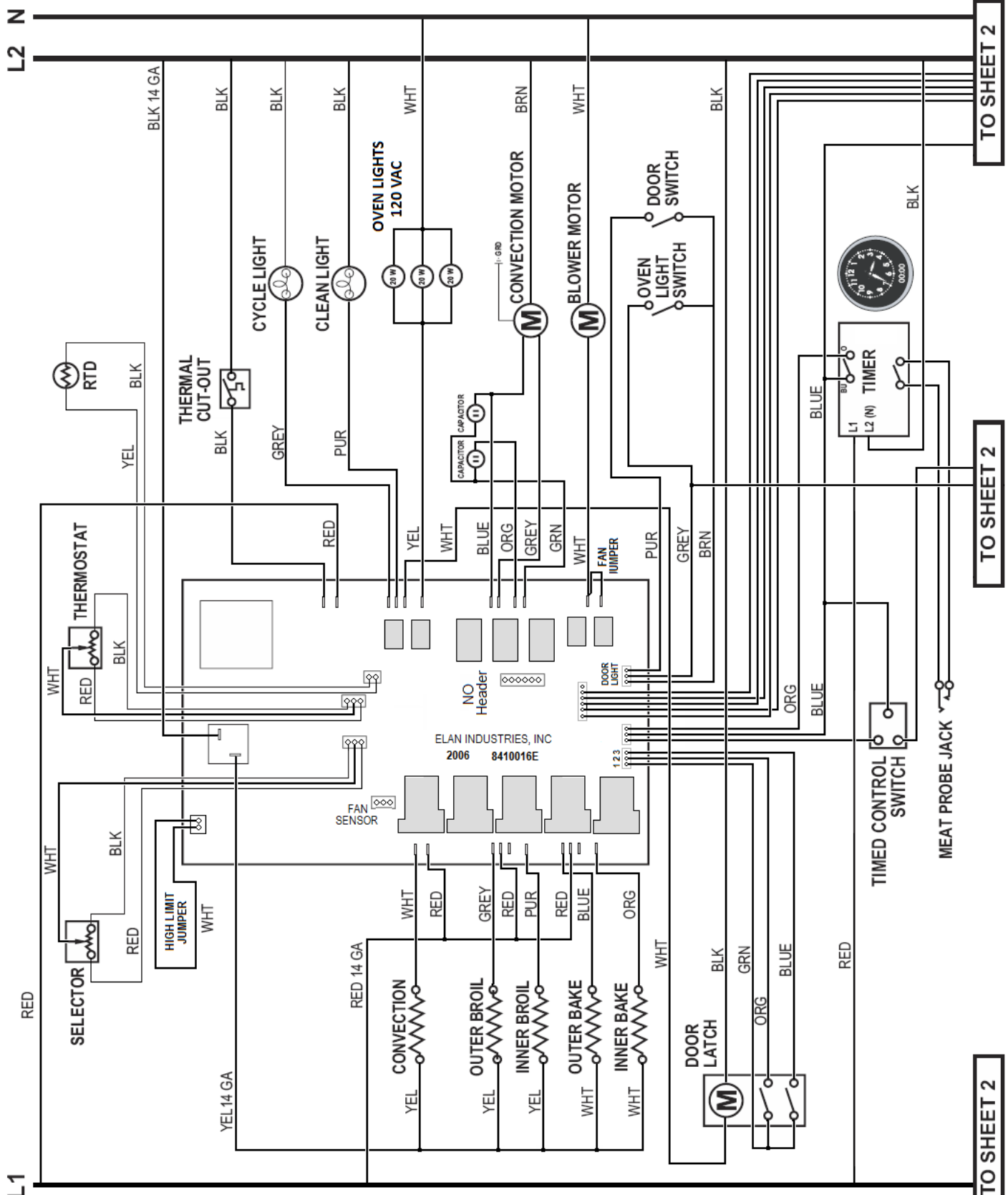

Designer Premiere Double Oven (Upper)

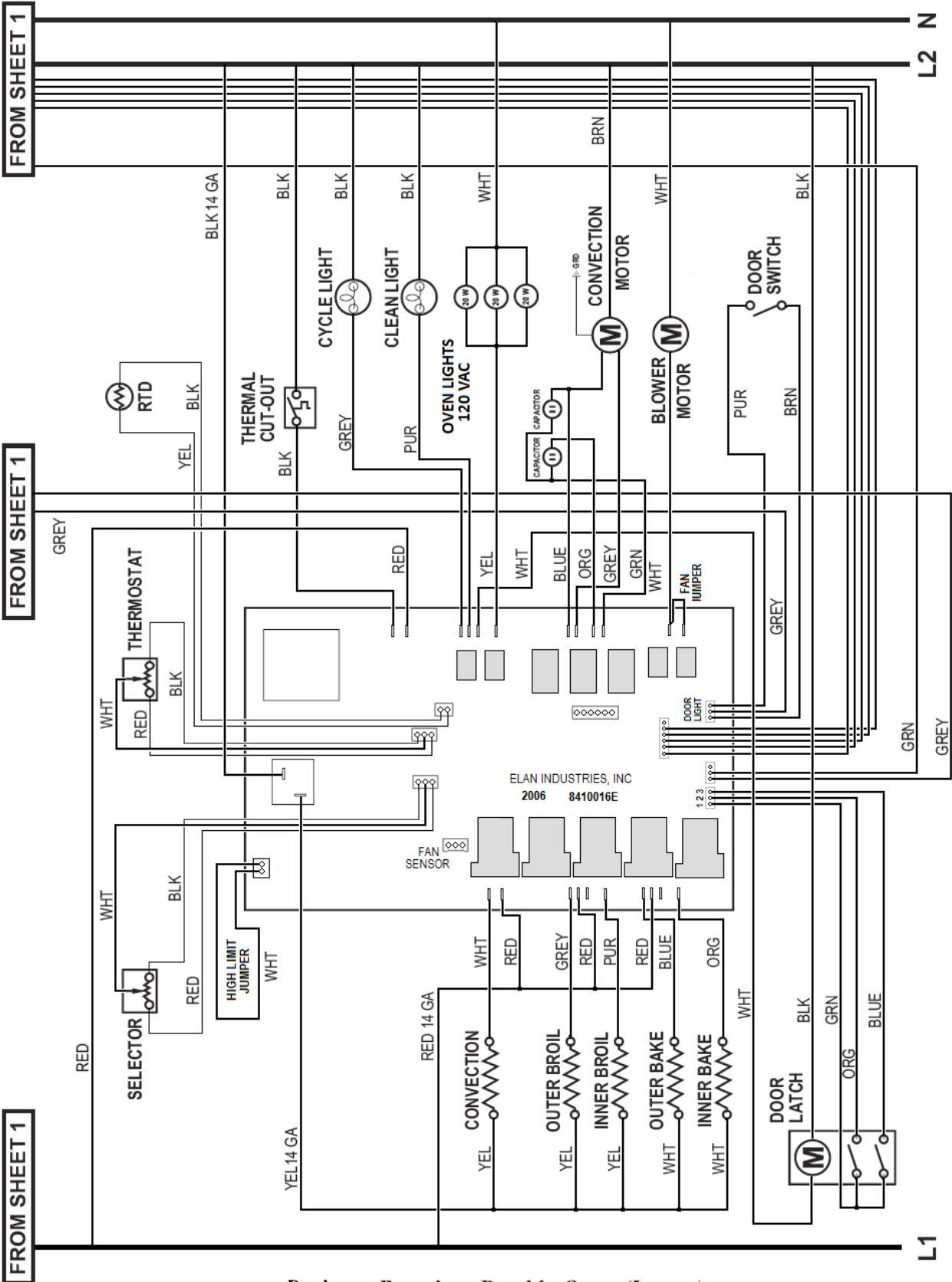

Designer Premiere Double Oven (Lower)

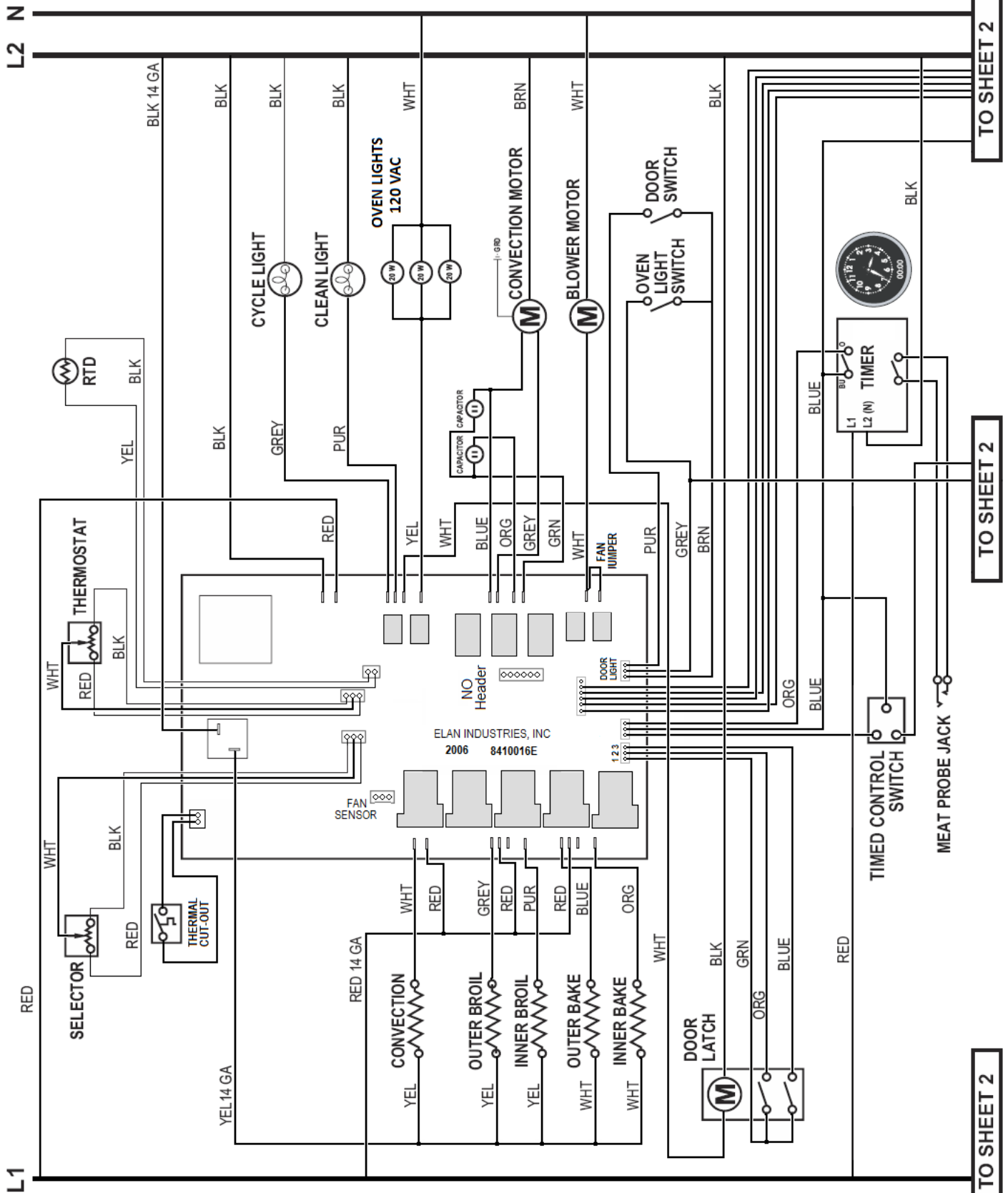

TO SHEET 2

TO SHEET 2

TO SHEET 2

Designer Premiere Double Oven (Upper)

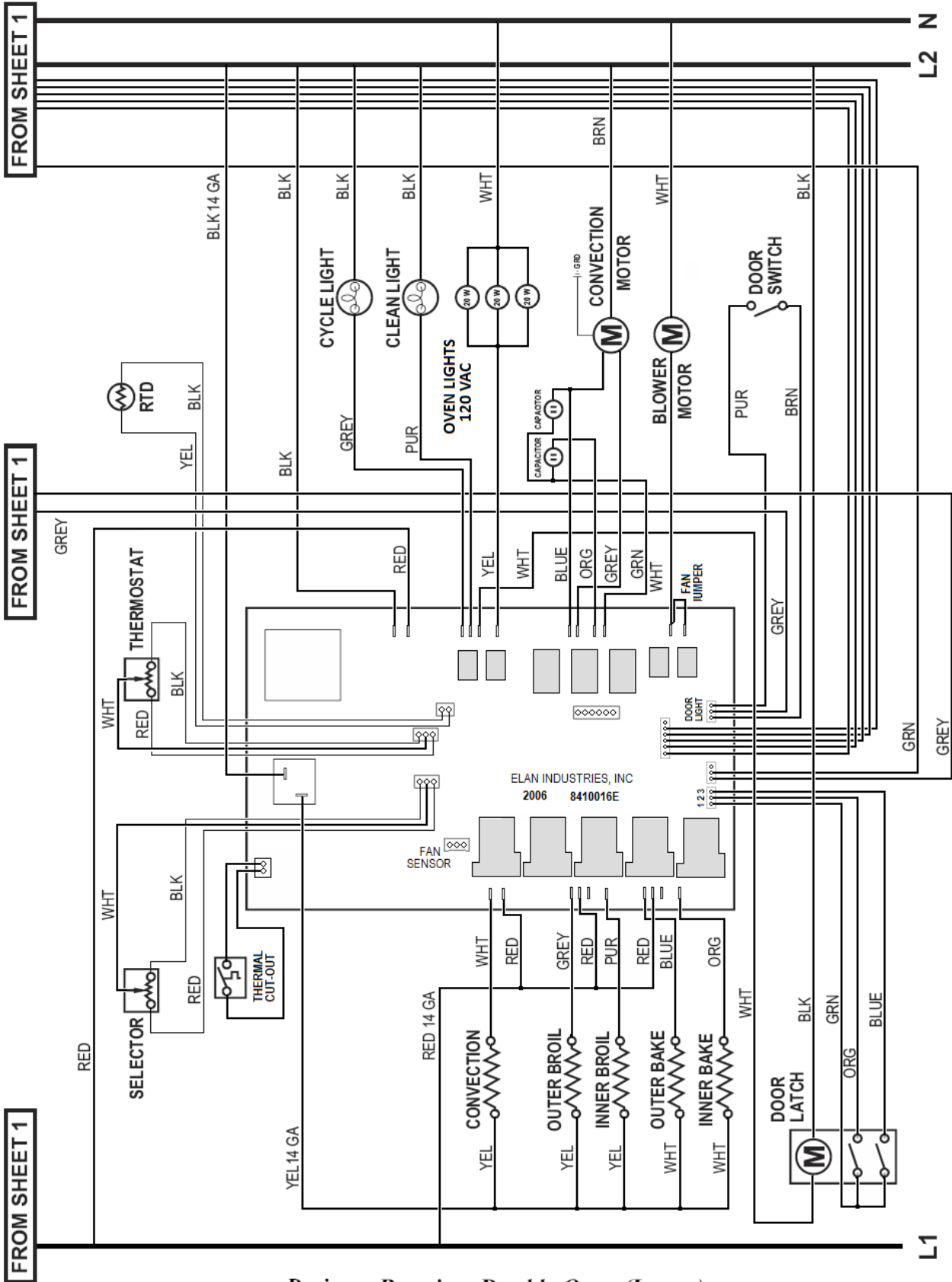

Designer Premiere Double Oven (Lower)